



**DUNNAIR**  
(Aust) Pty Ltd

**SH56**

**Split Ducted Model**

R410a Refrigerant

Performance Data

INDOOR COIL ENTERING AIR TEMP °C		OUTDOOR COIL ENTERING AIR TEMPERATURE °C											
		30°C			35°C			40°C			45°C		
		Tot Cap KW	Sens Cap KW	LWB °C	Tot Cap KW	Sens Cap KW	LWB °C	Tot Cap KW	Sens Cap KW	LWB °C	Tot Cap KW	Sens Cap KW	LWB °C
DB °C	WB °C												
21	17	54.9	33.6	11.2	51.9	32.4	11.6	49.0	31.2	11.9	46.6	31.2	12.2
	18	56.7	30.1	12.3	53.7	29.0	12.6	50.7	27.8	12.9	48.4	26.9	13.2
	19	58.6	26.6	13.4	55.6	25.4	13.7	52.5	24.1	14.1	50.2	23.2	14.3
	20	60.6	23.3	14.4	57.6	22.2	14.7	54.4	21.0	15.0	52.2	20.1	15.3
23	17	55.0	40.1	11.2	52.1	38.9	11.5	49.2	37.7	11.9	46.8	36.7	12.1
	18	56.6	36.5	12.2	53.7	35.4	12.6	50.7	34.2	12.9	48.3	33.3	13.2
	19	58.5	33.0	13.4	55.5	31.8	13.7	52.5	30.5	14.0	50.2	29.6	14.3
	20	60.6	29.7	14.4	57.5	28.6	14.7	54.4	27.4	15.0	52.2	26.5	15.3
	21	62.7	25.9	15.5	59.6	24.7	15.8	56.4	23.5	16.1	54.3	22.7	16.3
25	17	55.4	45.3	11.1	52.6	43.9	11.5	49.8	42.5	11.8	47.5	41.4	12.1
	18	56.4	44.3	12.1	53.4	41.9	12.5	50.4	40.8	12.8	48.0	39.9	13.0
	19	57.1	43.6	13.0	53.9	39.8	13.3	50.7	38.8	13.5	48.2	38.0	13.7
	20	57.7	43.0	13.7	54.4	37.8	13.9	51.1	36.9	14.2	48.5	36.3	14.3
	21	58.0	42.7	14.3	54.6	35.4	14.6	51.2	34.7	14.8	48.6	34.1	14.9
27	17	56.2	50.7	11.0	53.6	49.0	11.4	50.9	47.3	11.7	49.0	46.0	11.9
	18	57.2	48.6	12.2	54.4	47.2	12.5	51.5	45.9	12.8	50.0	44.9	13.1
	19	58.6	46.2	13.2	55.6	45.0	13.5	52.6	43.8	13.9	51.0	42.9	14.1
	20	60.5	42.6	14.3	57.4	41.4	14.7	54.3	40.2	15.0	52.1	39.4	15.2
	21	62.6	38.8	15.4	59.5	37.6	15.7	56.2	36.4	16.1	54.1	35.6	16.3
29	17	57.2	55.8	10.9	54.7	53.6	11.2	52.2	51.4	11.5	50.3	50.3	11.7
	18	58.2	53.7	12.0	55.5	52.0	12.3	52.7	50.3	12.7	50.3	50.3	12.9
	19	59.0	52.0	13.1	56.1	50.7	13.5	53.1	49.4	13.8	50.9	48.4	14.0
	20	60.6	48.8	14.3	57.5	47.6	14.6	54.4	46.4	14.9	52.2	45.5	15.2
	21	62.6	45.5	15.4	59.5	44.4	15.7	56.3	43.2	16.1	54.2	42.5	16.3
31	17	59.0	59.0	10.7	56.6	56.6	10.9	54.1	54.1	11.3	52.4	52.4	11.5
	18	59.5	58.0	11.9	56.9	55.9	12.2	54.1	54.1	12.5	52.4	52.4	12.7
	19	60.2	56.5	13.0	57.4	54.9	13.3	54.1	54.1	13.6	52.8	52.1	13.9
	20	61.0	55.4	14.3	58.0	54.2	14.6	54.9	53.0	14.9	52.9	52.9	15.1
	21	62.6	52.2	15.3	59.6	51.2	15.6	56.3	50.0	15.9	54.3	49.3	16.2

Capacity multipliers should be applied to the above capacities to adjust for reduced or increased air flow.



### Technical Specification SH56 Split Ducted Model

Indoor Unit Model Number	SH56N	Nominal Evaporator Air Flow (l/s)	3000
Outdoor Unit Model Number	SH56W	Number of Compressors	2
Total Cooling Capacity (kW)*	55.6	Power Requirements (Volt / Phase)	415 / 3
Sensible Cooling Capacity (kW)*	45.0	Normal Max. Current (Amps / Phase)	41.7
Heating Capacity (kW)**	57.4		

\*Entering air @ 27/19°C and ambient 35°C      \*\* Entering air @ 21°C DB and 7°C ambient

### Air Quantity Multiplying Factors

Capacity	% Rated Air Quantity-Nominal 3000 l/s				
	80	90	100	110	120
Total	0.95	0.98	1.00	1.02	1.04
Sensible	0.89	0.95	1.00	1.05	1.09

### Heating Performance Data

Heating Capacity kW	Outdoor Coil Entering DB temp				
	0	4	8	12	18
	54.3	59.4	68.5	75.0	89.4

### Heating Performance Correction

% Rated Air Quality	Multiplier	Return Air Temp °C	Multiplier	Outdoor Air Temp °C	Approx. Defrost Factor
80	0.93	15	1.05	0	0.80
90	0.97	18	1.03	2	0.78
100	1.00	21	1.00	4–6	0.75
110	1.03	24	0.97	7	0.87
120	1.05	27	0.95	8	1.00

### Compressor

Number Per Unit	2
Type	Scroll
RPM (Nom)	2900
Normal Max. Current (Amps / Phase)	2 × 15.0
Locked Rotor Current (Amps / Phase)	2 × 112
Displacement (m³/h)	2 × 30.4

### Electrical Controls and Safeties

High Pressure Switch (Setting kPa)	2800	Defrost	
Low Pressure Switch (Setting kPa)	100	Initiation Temperature (°C)	-4
Indoor Fan Overload	Internal	Termination Temperature (°C)	10
Outdoor Fan Overload	Internal	Min. Period Between De-Ice (min)	33
Compressor Delay Timer	300 sec	Max. De-Ice Period (min)	4

### Standard Features

Manual reset high pressure and auto reset low pressure cutouts	
Thermal overload protection on all motors	Suction line accumulator
Compressor crankcase heater	Automatic de-ice system
Limit start timer (anti short cycling)	Thermally insulated indoor unit

### Indoor Coil

Type	Copper Tube / Aluminium Fins
Face Area (m)	1.07
Air Quantity (l/s)	3000

### Indoor Fan

Number of Fans	1
Type	Centrifugal
Drive	Belt
Motor Voltage / Phase / Frequency	415 / 3 / 50
Motor (kW) Standard	4.0
Max. Fan Speed (rpm)	870

### Electrical

Power Requirements	3 Phase / 415V / 50Hz
Normal Max. Current (Amps / Phase)	41.7

### Outdoor Coil

Type	Copper Tube / Aluminium Fins
Face Area	2 × 1.03

### Outdoor Fan

Number of Fans	4
Type	Axial
Drive	Direct
Motor Watts / rpm	4 × 200 / 950
Motor Voltage / Phase / Frequency	415 / 3 / 50

### Refrigerant System

Refrigerant Type	R410a
Charge (kg)	2 × 7.4
Line Size (mm)	
Liquid 0–10 metres	19
Gas 0–10 metres	28
Liquid 10–20 metres	22
Gas 10–20 metres	28
Service Connections	Rotor Lock Valve
Expansion Control – in outdoor unit	TX Valve

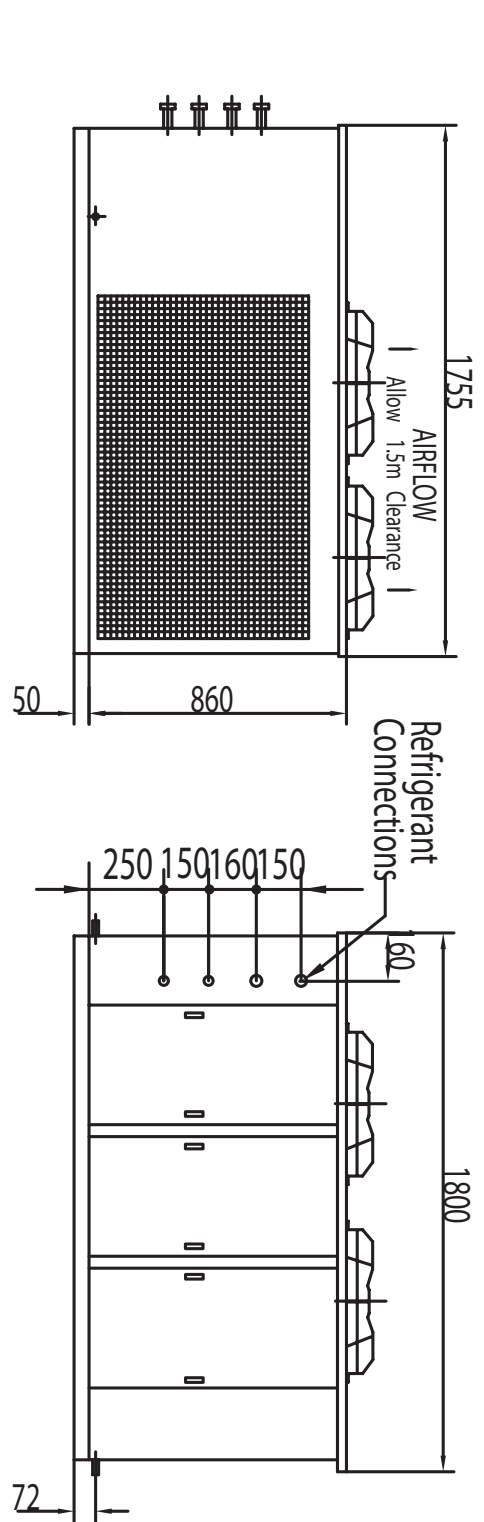

OUTDOOR UNIT INSTALLED WEIGHT 532 kg  
 For units with  
 R410a/R407C/R22

DRAWN BY: Chen Cheng	DATE: 7th Jan.10	TITLE: Split System Air Cooled Heat Pump Unit	
APPROVED O.A.: Li Meifen	APPROVED ENG.: Zhang Jingfei	SH TYPE	
MODEL: SH56WBb2	DRAWING NO.: 01	ISSUE: 01	SHEET SIZE: A4

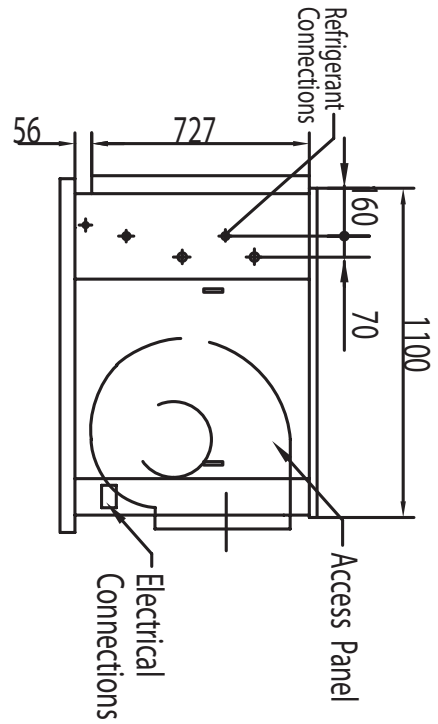
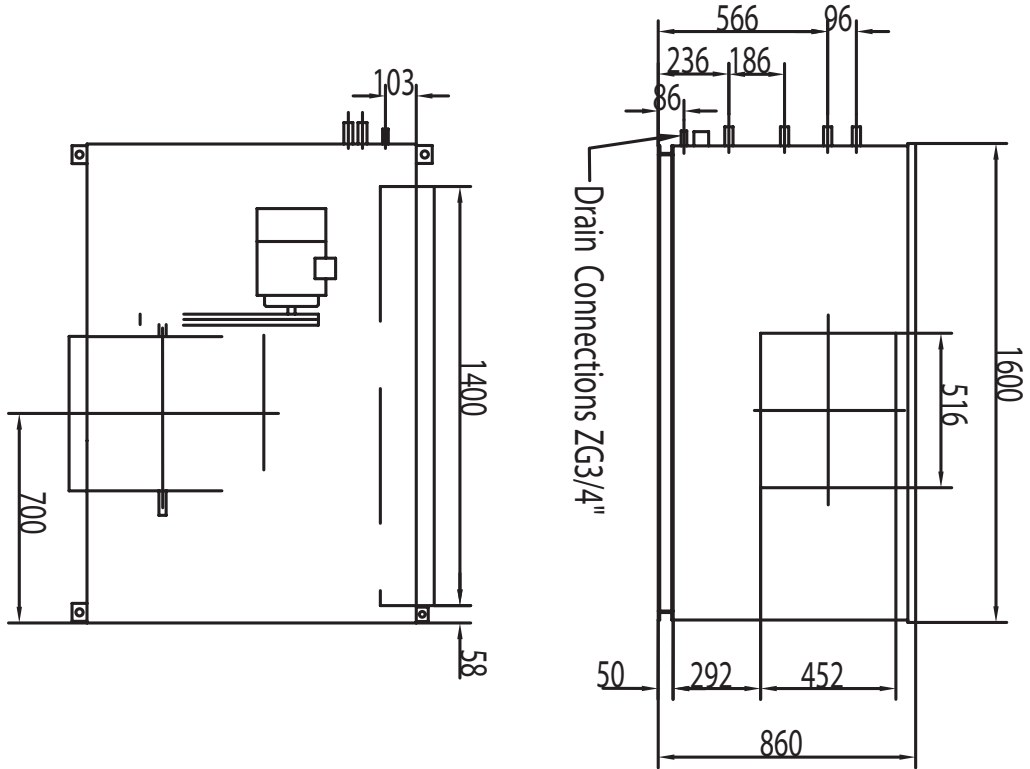

For units with  
R410a/R407C/R22

- Fan : KDFQ4.0
- Motor: Y112M-4 (4.0kW-4)
- Fan pulley: 35-B2-230
- Motor pulley: 28-B2-140
- Fan speed: 870rpm

INDOOR UNIT INSTALLED WEIGHT 290 kg

DRAWN BY: Chen Cheng	DATE: 7th Jan.10		
APPROVED Q.A.: LI Meifen	APPROVED ENG.: Zhang Jingfei	TITLE: Split System Air Cooled Heat Pump Unit	
MODEL: SHS56NBb2		SHEET SIZE: A4	
DRAWING NO.: 01	ISSUE: 01		
<b>SH TYPE</b>			

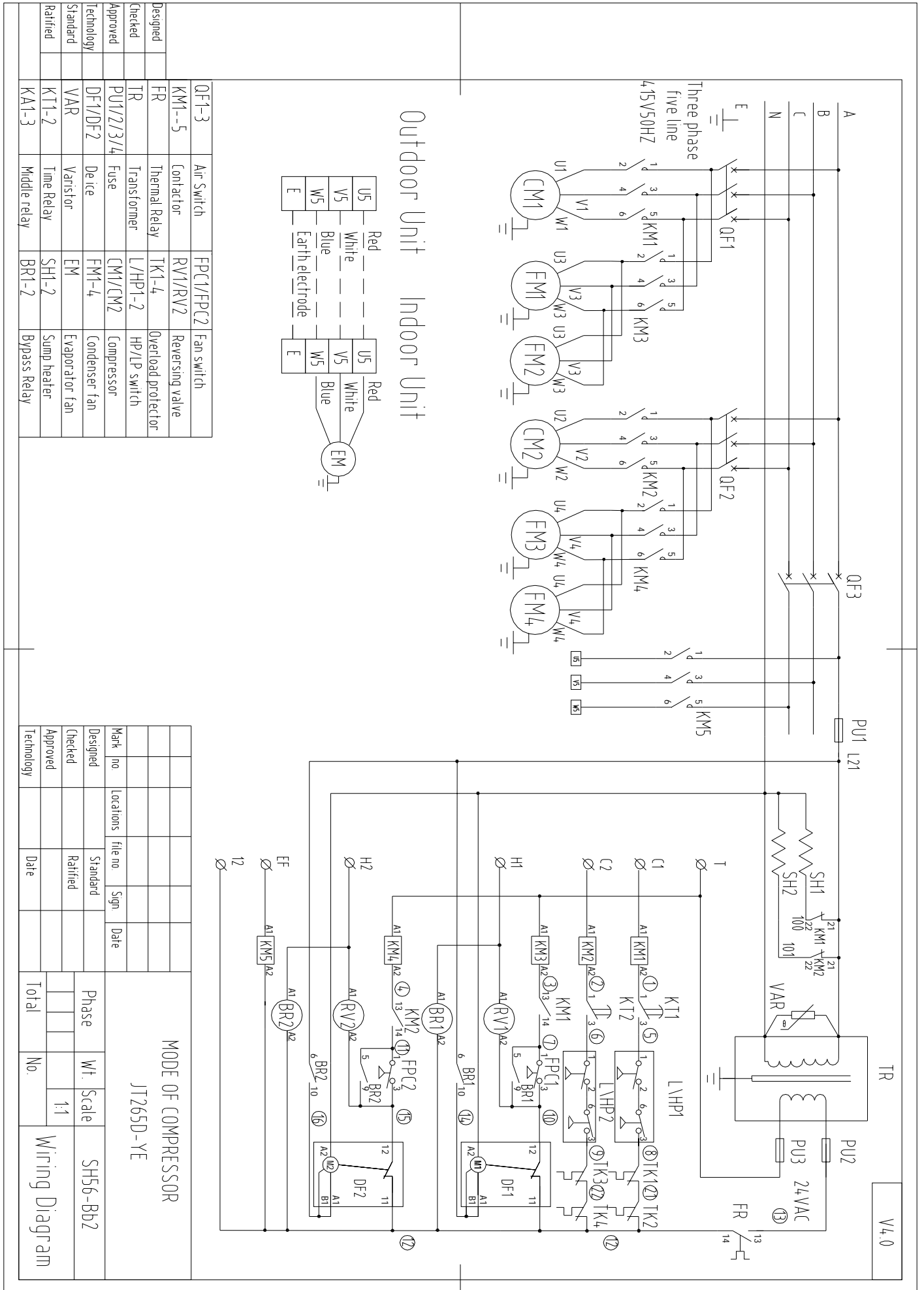

Designed	QF1-3	Air Switch	FPC1/FPC2	Fan switch
Checked	KM1-5	Contactors	RV1/RV2	Reversing valve
Approved	FR	Thermal Relay	TK1-4	Overload protector
Technology	TR	Transformer	L/HP1-2	HP/LP switch
Standard	PU1/2/3/4	Fuse	CM1/CM2	Compressor
Ratified	DF1/DF2	Device	EM1-4	Condenser fan
	VAR	Varistor	EM	Evaporator fan
	KT1-2	Time Relay	SH1-2	Sump heater
	KA1-3	Middle relay	BR1-2	Bypass Relay

Mark no	Locations	file no	Sign	Date
Designed		Standard		
Checked		Ratified		
Approved				
Technology		Date		

MODE OF COMPRESSOR	
JT65D-YE	
Phase	Wt. Scale
	1:1
Total	No.

SH56-Bb2

Wiring Diagram

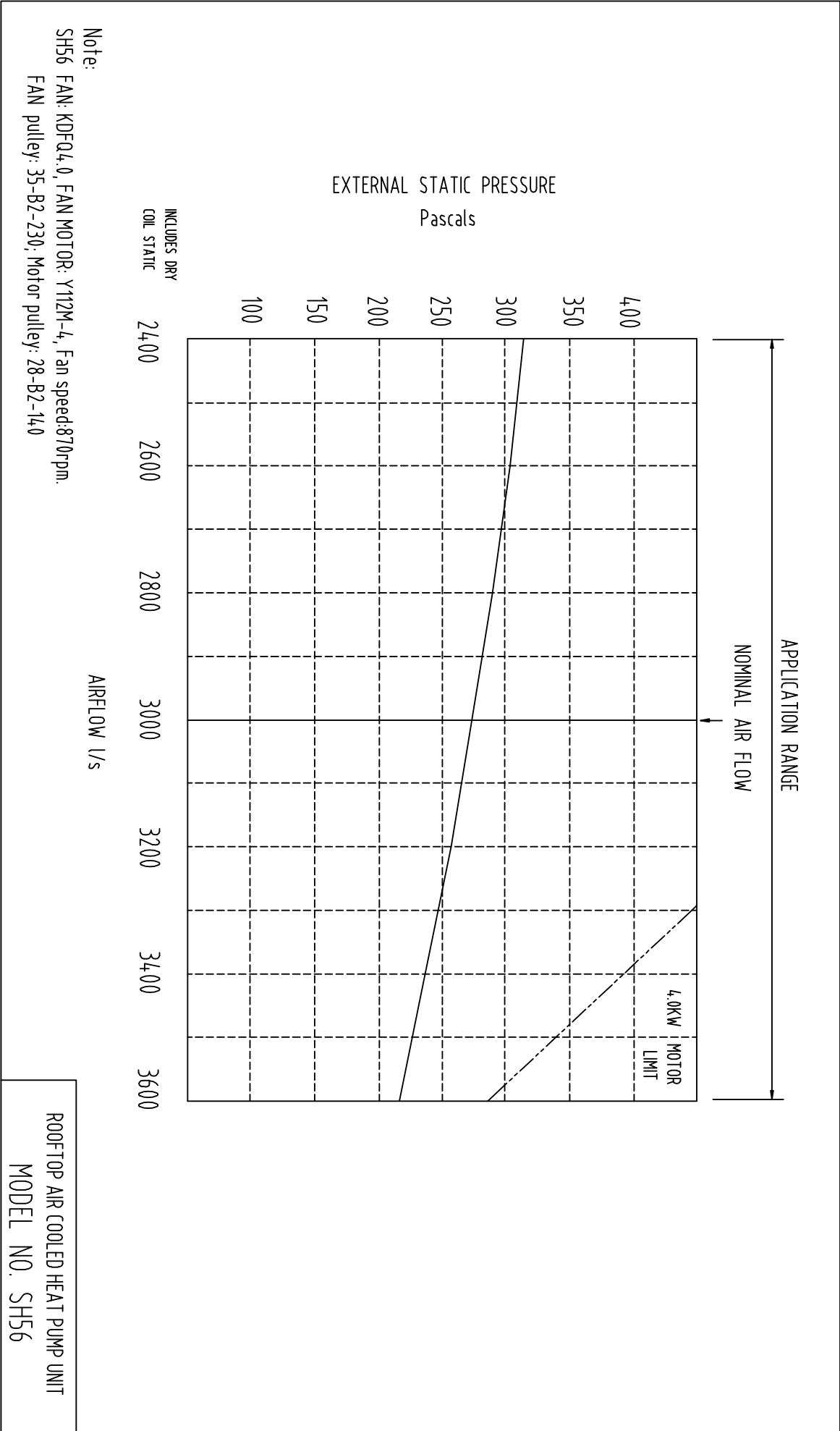

SH56W Noise rate analysing chart

A Class: 77.1dB

Hz	dB
64Hz	82.5
125Hz	80.1
250Hz	77.6
500Hz	72.8
1000Hz	73.4
2000Hz	66.8
4000Hz	63.3
8000Hz	52.2

Noise rate analysing chart ( A Class: 77.1dB) dB

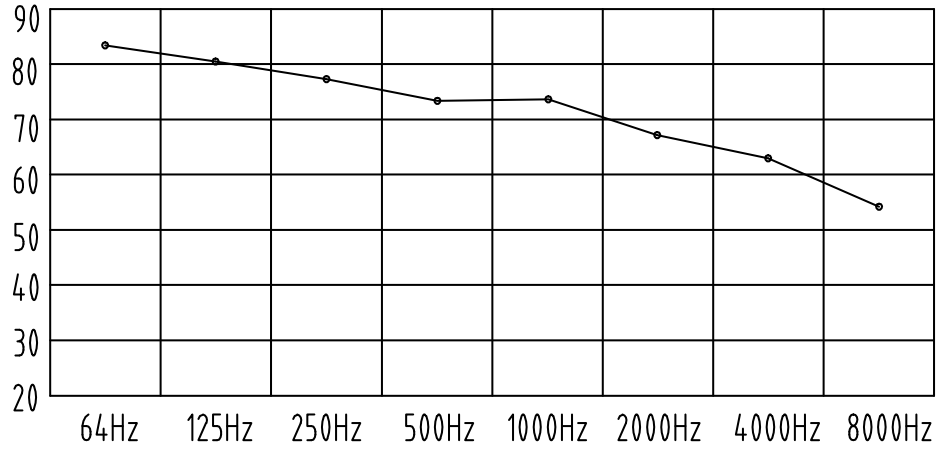

SH56N Noise rate analysing chart

A Class: 72.8dB

Hz	dB
64Hz	79.9
125Hz	79.2
250Hz	71.8
500Hz	68.5
1000Hz	68.1
2000Hz	64.1
4000Hz	61.0
8000Hz	53.8

Noise rate analysing chart ( A Class: 72.8dB) dB

