



DUNNAIR
(Aust) Pty Ltd

R410a Refrigerant

SH50

Split Ducted Model

Performance Data

INDOOR COIL ENTERING AIR TEMP °C		OUTDOOR COIL ENTERING AIR TEMPERATURE °C											
		30°C			35°C			40°C			45°C		
		Tot Cap KW	Sens Cap KW	LWB °C	Tot Cap KW	Sens Cap KW	LWB °C	Tot Cap KW	Sens Cap KW	LWB °C	Tot Cap KW	Sens Cap KW	LWB °C
DB °C	WB °C												
21	17	47.8	29.7	11.4	45.2	28.6	11.8	42.8	27.6	12.1	40.3	27.6	12.4
	18	49.4	26.5	12.0	46.8	25.5	12.8	44.4	24.5	13.2	41.9	23.5	13.5
	19	51.1	23.5	13.5	48.5	22.5	13.8	46.0	21.5	14.1	43.5	20.6	14.4
	20	53.0	20.2	14.6	50.3	19.1	14.9	47.7	18.1	15.3	45.3	17.1	15.5
23	17	47.9	35.6	11.4	45.4	34.6	11.7	43.0	33.6	12.0	40.5	32.5	12.3
	18	49.4	32.4	12.5	46.8	31.3	12.8	44.3	30.3	13.1	41.8	29.3	13.5
	19	51.1	29.3	13.5	48.5	28.3	13.8	46.0	27.4	14.1	43.5	26.4	14.4
	20	52.9	26.0	14.6	50.3	24.9	14.9	47.7	23.9	15.3	45.3	22.9	15.5
	21	54.9	23.2	15.7	52.2	22.2	16.0	49.6	21.2	16.3	47.2	20.4	16.6
25	17	48.4	40.6	11.3	46.0	39.4	11.6	43.7	38.2	11.9	41.2	37.0	12.2
	18	49.5	39.4	12.4	46.9	37.4	12.7	44.5	36.4	13.1	42.0	25.4	13.4
	19	51.1	37.7	13.5	48.4	34.2	13.8	45.9	33.2	14.1	43.5	32.3	14.4
	20	52.9	35.7	14.6	50.2	30.8	14.9	47.6	29.8	15.2	45.2	28.8	15.5
	21	54.9	33.4	15.7	52.2	28.1	16.0	49.5	27.1	16.3	47.1	26.2	16.6
27	17	49.2	45.0	11.2	46.9	43.6	11.4	44.7	42.1	11.7	42.4	40.7	12.0
	18	50.0	43.5	12.3	47.5	42.3	12.7	45.1	41.2	13.0	42.7	40.1	13.3
	19	51.2	40.8	13.5	48.6	39.8	13.8	46.1	38.8	14.1	43.6	37.9	14.4
	20	52.8	37.7	14.6	50.2	36.6	14.9	47.6	35.6	15.2	45.2	34.6	15.5
	21	54.8	34.9	15.7	52.1	33.9	16.0	49.5	33.0	16.3	47.1	32.1	16.6
29	17	50.4	49.0	11.0	48.2	47.2	11.2	46.0	45.4	11.5	43.9	43.7	11.8
	18	51.0	47.6	12.2	48.6	46.2	12.5	46.3	44.8	12.8	44.0	43.5	13.1
	19	51.6	46.6	13.5	49.1	45.6	13.8	46.6	44.6	14.1	44.2	43.0	14.4
	20	52.9	44.1	14.6	50.3	43.1	14.9	47.7	42.1	15.3	45.3	41.1	15.6
	21	54.8	40.8	15.7	52.1	39.8	16.0	49.4	38.8	16.3	47.0	37.9	16.6
31	17	52.0	52.0	10.8	49.9	49.9	11.0	47.9	47.9	11.3	45.9	45.9	11.6
	18	52.3	51.2	12.2	50.1	49.5	12.5	47.9	47.8	12.8	45.9	45.9	13.0
	19	52.7	50.4	13.3	50.3	49.1	13.6	47.9	47.8	13.9	45.9	45.9	14.2
	20	53.3	49.8	14.4	50.7	48.7	14.8	48.2	47.7	15.1	45.9	45.9	15.4
	21	54.8	46.5	15.7	52.1	45.5	16.0	49.5	44.5	16.3	47.1	43.6	16.6

Capacity multipliers should be applied to the above capacities to adjust for reduced or increased air flow.

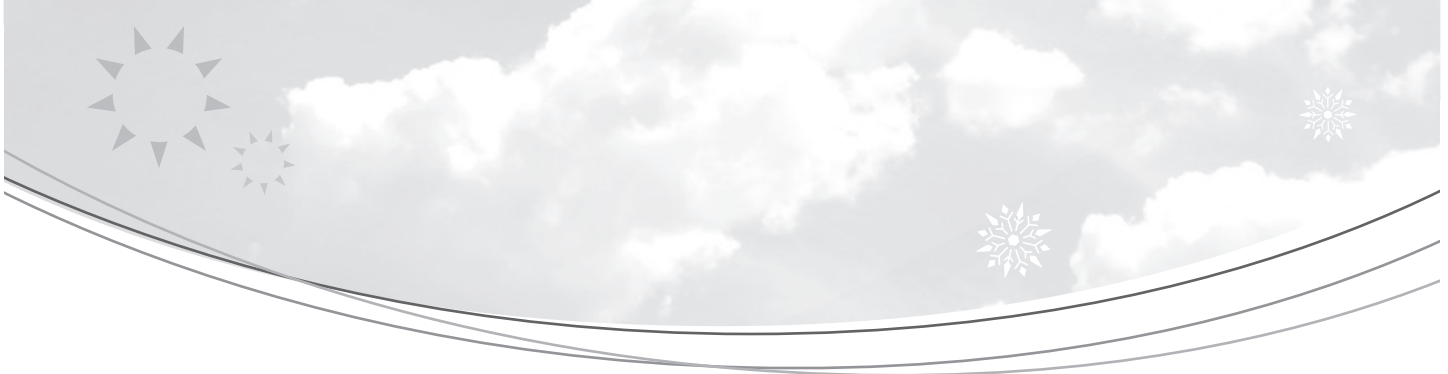

Technical Specification SH50 Split Ducted Model

Indoor Unit Model Number	SH50N	Nominal Evaporator Air Flow (l/s)	2800
Outdoor Unit Model Number	SH50W	Number of Compressors	2
Total Cooling Capacity (kW)*	48.6	Power Requirements (Volt / Phase)	415 / 3
Sensible Cooling Capacity (kW)*	39.8	Normal Max. Current (Amps / Phase)	38.9
Heating Capacity (kW)**	44.2		

*Entering air @ 27/19°C and ambient 35°C ** Entering air @ 21°C DB and 7°C ambient

Air Quantity Multiplying Factors

% Rated Air Quantity-Nominal 2800 l/s					
Capacity	80	90	100	110	120
Total	0.95	0.98	1.00	1.02	1.04
Sensible	0.89	0.95	1.00	1.05	1.09

Heating Performance Data

Outdoor Coil Entering DB temp					
	0	4	8	12	18
Heating Capacity kW	34.9	38.8	44.9	49.5	59.6

Heating Performance Correction

% Rated Air Quality	Multiplier	Return Air Temp °C	Multiplier	Outdoor Air Temp °C	Approx. Defrost Factor
80	0.93	15	1.05	0	0.80
90	0.97	18	1.03	2	0.78
100	1.00	21	1.00	4–6	0.75
110	1.03	24	0.97	7	0.87
120	1.05	27	0.95	8	1.00

Compressor

Number Per Unit	2
Type	Scroll
RPM (Nom)	2900
Normal Max. Current (Amps / Phase)	2 × 13.6
Locked Rotor Current (Amps / Phase)	2 × 95
Displacement (m³/h)	2 × 27.5

Electrical Controls and Safeties

High Pressure Switch (Setting kPa)	2800	Defrost	
Low Pressure Switch (Setting kPa)	100	Initiation Temperature (°C)	-4
Indoor Fan Overload	Internal	Termination Temperature (°C)	10
Outdoor Fan Overload	Internal	Min. Period Between De-Ice (min)	33
Compressor Delay Timer	300 sec	Max. De-Ice Period (min)	4

Standard Features

Manual reset high pressure and auto reset low pressure cutouts	
Thermal overload protection on all motors	Suction line accumulator
Compressor crankcase heater	Automatic de-ice system
Limit start timer (anti short cycling)	Thermally insulated indoor unit

Indoor Coil

Type	Copper Tube / Aluminium Fins
Face Area (m)	1.07
Air Quantity (l/s)	2800

Indoor Fan

Number of Fans	1
Type	Centrifugal
Drive	Belt
Motor Voltage / Phase / Frequency	415 / 3 / 50
Motor (kW) Standard	3.0
Max. Fan Speed (rpm)	850

Electrical

Power Requirements	3 Phase / 415V / 50Hz
Normal Max. Current (Amps / Phase)	38.9

Outdoor Coil

Type	Copper Tube / Aluminium Fins
Face Area	2 × 1.03

Outdoor Fan

Number of Fans	4
Type	Axial
Drive	Direct
Motor Watts / rpm	4 × 200 / 950
Motor Voltage / Phase / Frequency	415 / 3 / 50

Refrigerant System

Refrigerant Type	R410a
Charge (kg)	2 × 7.2
Line Size (mm)	
Liquid 0–10 metres	19
Gas 0–10 metres	29
Liquid 10–20 metres	22
Gas 10–20 metres	28
Service Connections	Rotor Lock Valve
Expansion Control – in outdoor unit	TX Valve

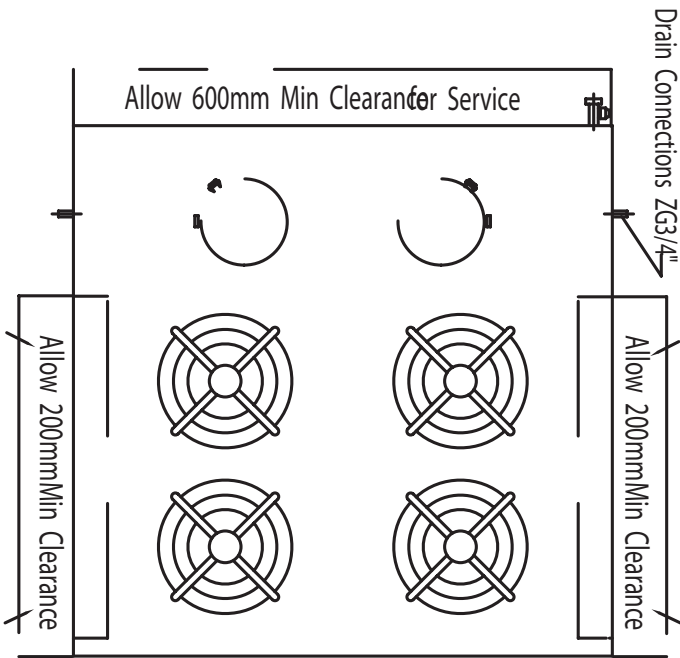
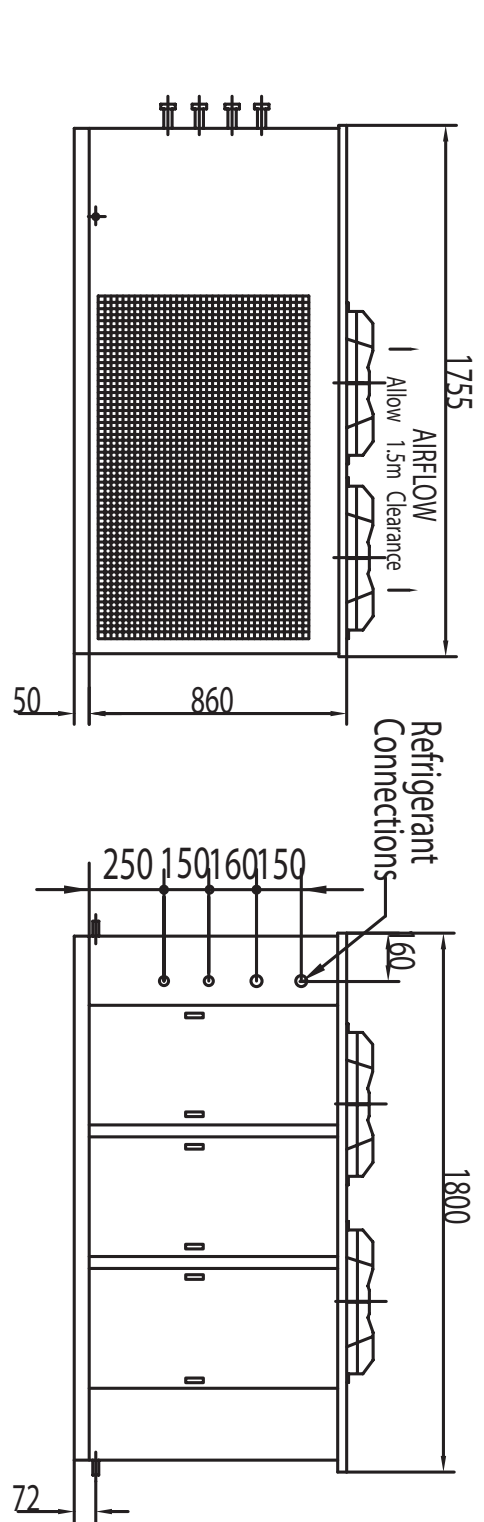

OUTDOOR UNIT INSTALLED WEIGHT 530 kg
 For units with
 R410a/R407C/R22

DRAWN BY: Chen Cheng	DATE: 7th Jan.10	TITLE: Split System Air-Cooled Heat Pump Unit	
APPROVED O.A.: Li Meifen	APPROVED ENG.: Zhang Jingfei	SH TYPE	
MODEL: SH50WBb2	DRAWING NO.: 01	ISSUE: 01	SHEET SIZE: A4

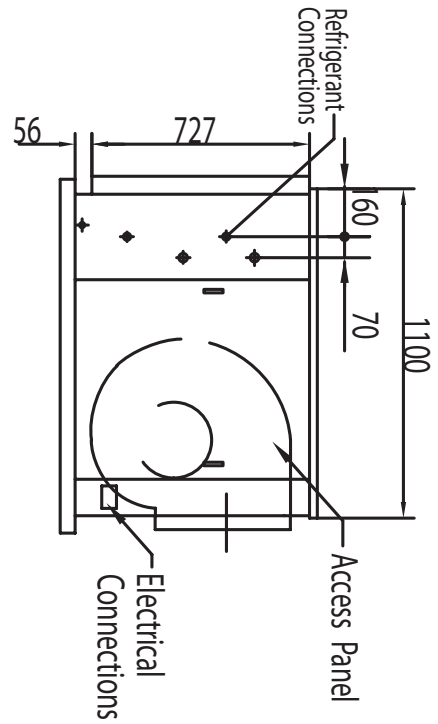
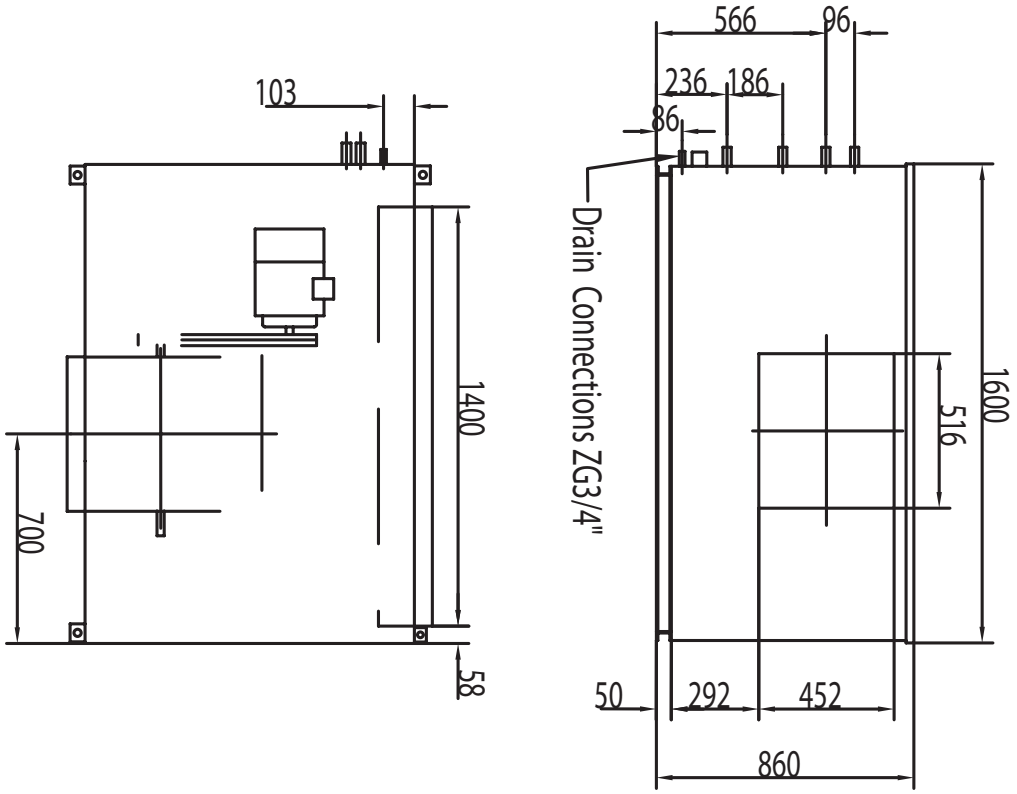

For units with
R410a/R407C/R22

- Fan : KDFQ4.0
- Motor: Y1100L2-4 (3.0kW-4)
- Fan pulley: 35-A2-165
- Motor pulley: 28-A2-100
- Fan speed: 850rpm

INDOOR UNIT INSTALLED WEIGHT 290 kg

DRAWN BY: Chen Cheng		DATE: 7th Jan.10	
APPROVED Q.A.: Li Meifen		APPROVED ENG.: Zhang Jingfei	
TITLE: Split System Air Cooled Heat Pump Unit SH TYPE			
MODEL: SHS50NBb2	DRAWING NO.: 01	ISSUE: 01	SHEET SIZE: A4

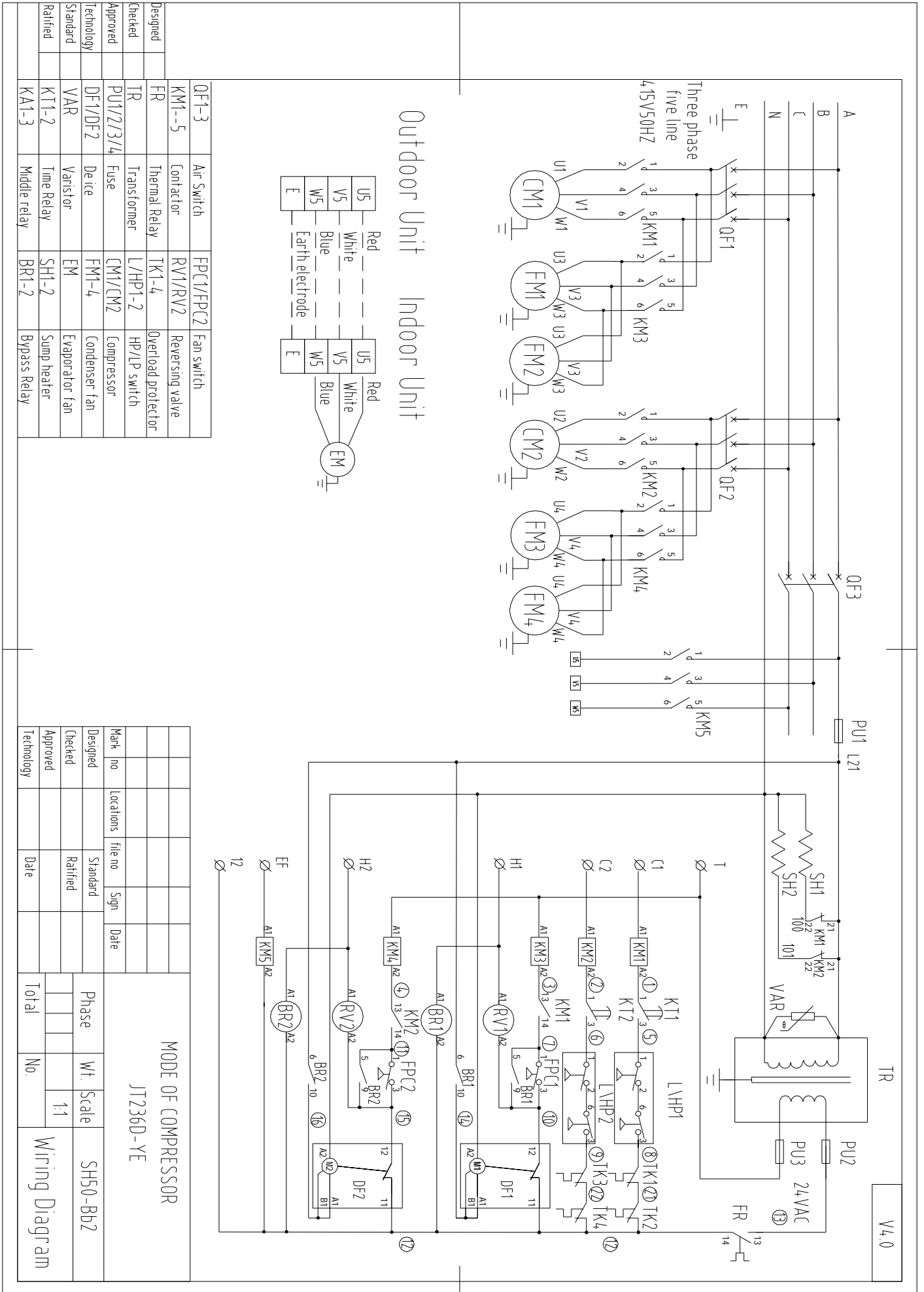

Outdoor Unit Indoor Unit

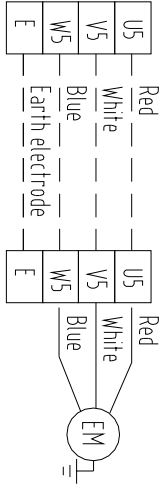

Designed	QF1-3	Air Switch	FPC1/FPC2	Fan switch
Checked	KM1-5	Contactors	RV1/RV2	Reversing valve
Approved	FR	Thermal Relay	TK1-4	Overload protector
Technology	TR	Transformer	L/HP1-2	HP/LP switch
Standard	PU1/2/3/4	Fuse	CM1/CM2	Compressor
Ratified	DF1/DF2	De ice	FM1-4	Condenser fan
	VAR	Varistor	EM	Evaporator fan
	KT1-2	Time Relay	SH1-2	Sump heater
	KA1-3	Middle relay	BR1-2	Bypass Relay

Designed	Mark no	Locations	file no	Sign	Date
Checked					
Approved					
Technology					

MODE OF COMPRESSOR	
JT236D-YE	
Phase	Wt. Scale
	1:1
Total	No.
Wiring Diagram	

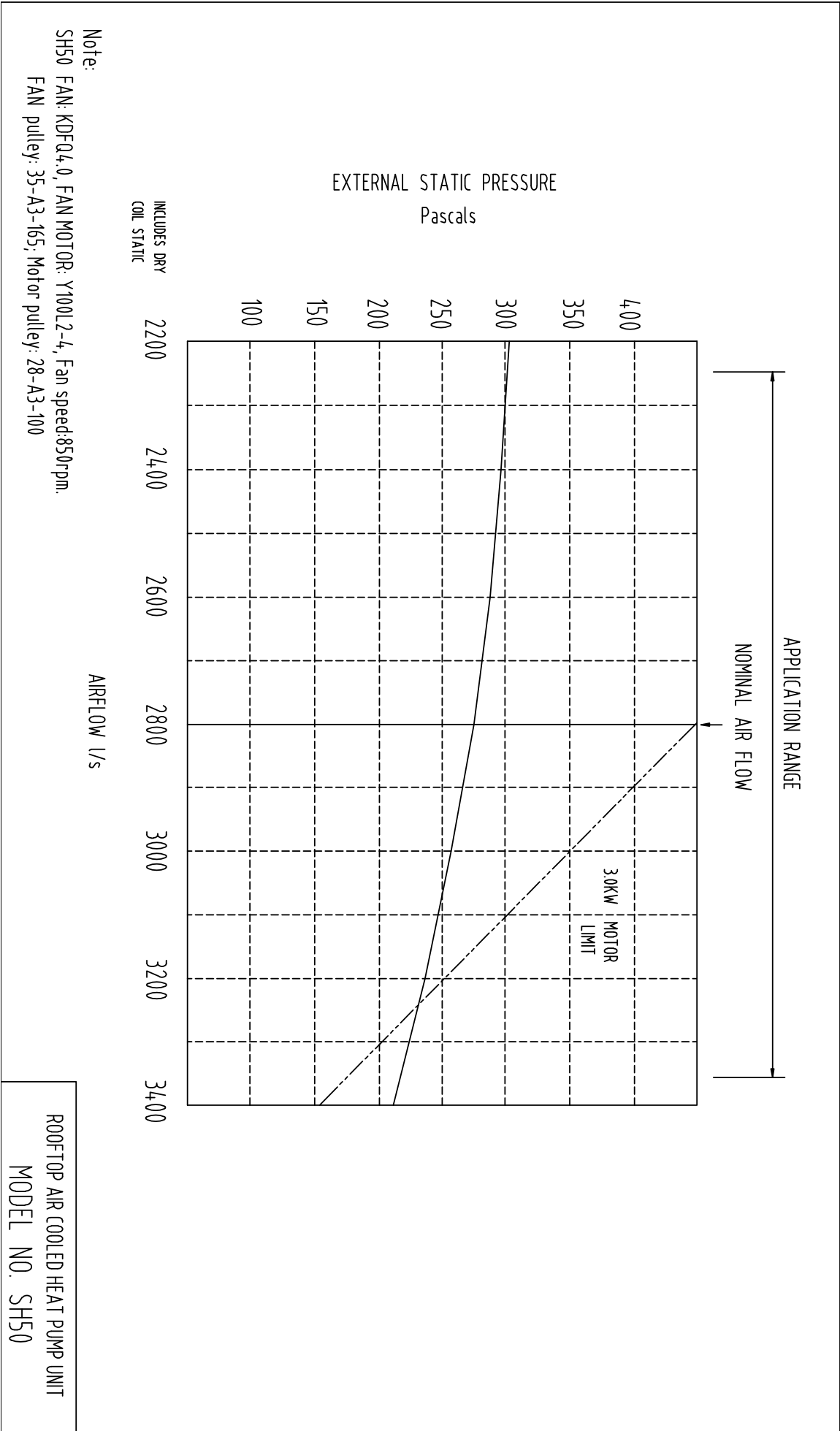

SH 50W Noise rate analysing chart

A Class: 76.7dB

Hz	dB
64Hz	82.5
125Hz	79.5
250Hz	76.7
500Hz	74.3
1000Hz	72.2
2000Hz	67.2
4000Hz	61.3
8000Hz	52.6

Noise rate analysing chart (A Class: 76.7dB) dB

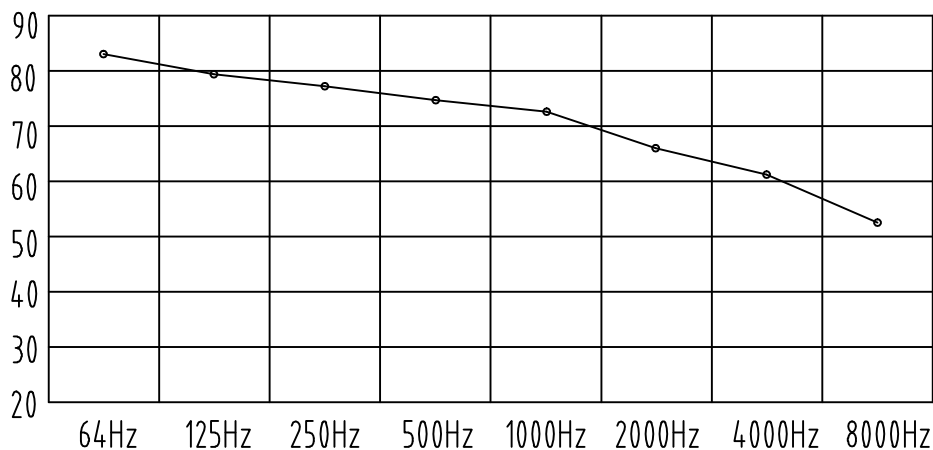

SH 50N Noise rate analysing chart

A Class: 72.8dB

Hz	dB
64Hz	80.2
125Hz	78.6
250Hz	73.8
500Hz	68.3
1000Hz	67.6
2000Hz	63.3
4000Hz	61.4
8000Hz	54.3

Noise rate analysing chart (A Class: 72.8dB) dB

