



DUNNAIR
(Aust) Pty Ltd

WPR52L

R410a Refrigerant

Vertical Water Cooled Packaged

TECHNICAL SPECIFICATION

Total Cooling Capacity	52.5 kW	Refrigerant	R410A
Electrical Input (Cooling)	13.1kW	Refrigerant Charge	3*1.9kg
E.E.R.(Cooling)	4.0	Minimum Water Flow	2.48 l/s
Running Amps (Total)	33.1A	Water Coil Pressure Drop	52kPa
Fan Motor Full Load Amps	3.7A	Filter (Option)	EU1
Electrical Supply Required	3 Ph.415V.50Hz	Electric Heat (Option)	36 kW

COOLING CAPACITY (kW)

AIR FLOW RATE (L/S)		2400			
COIL E.A.T.	DB °C	23	27	31	
		WB °C	17	19	21
Entering Water Temperature (E.W.T) °C	20	T	55.8	58.7	62.2
		S	38.3	43.4	48.4
		FL	3.1	3.1	3.1
		HR	68.7	71.5	75.3
	25	T	53.1	56.4	62.1
		S	38.6	42.5	48.4
		FL	3.1	3.1	3.1
		HR	66.1	69.2	75.3
	30	T	49.9	52.5	58.6
		S	35.6	41.7	46.9
		FL	3.1	3.1	3.1
		HR	62.7	65.6	72.1
	35	T	46.6	49.1	51.1
		S	34.2	39.3	43.8
		FL	3.1	3.1	3.1
		HR	59.7	62.3	64.5
40	T	44.5	45.7	47.9	
	S	33.2	37.8	42.6	
	FL	3.1	3.1	3.1	
	HR	58.1	59.0	61.8	

T = Total Capacity (kW)

S = Sensible Capacity (kW)

FL = Water Flow (l/s)

E.A.T.= Entering Air Temperature (°C)

__ = Nominal Capacity (kW)

HR = Heat Rejection

Note: 1. Capacities are gross and do not include allowance for fan motor heat loss. For fan motor heat loss refers to Air Handling Performance.

2. Water flow and cooling capacity based on 5°C water temperature difference

HEATING CAPACITY (kW)

WPR Reverse Cycle Version

AIR FLOW RATE (L/S)		2400			
WATE FLOW RATE (L/S)		3.1			
COIL E.A.T.	DB °C	18	21	25	
Entering Water Temperature (E.W.T) °C	15	HC	50.7	50.0	48.0
		Hab	38.1	37.4	35.5
		LWT	11.1	11.1	11.3
		INPT	12.6	12.6	12.5
	20	HC	53.7	50.6	50.6
		Hab	40.7	40.0	38.0
		LWT	15.9	15.9	16.1
		INPT	13.0	13.0	12.6
	25	HC	58.5	57.4	55.6
		Hab	44.4	44.0	42.2
		LWT	20.5	20.6	20.7
		INPT	14.1	13.4	13.4

HC = Heating Capacity (kW)

Hab = Heat Absorbed (kW)

L.W.T.= Leaving Water Temperature (°C)

E.A.T.= Entering Air Temperature (°C)

INPT = Compressor Input Power (kW)

__ = Nominal Capacity (kW)

Note: All units are reverse cycle heat pump units. Models can also be provided as cooling only or cooling with electric heater.

DIMENSIONS (mm)

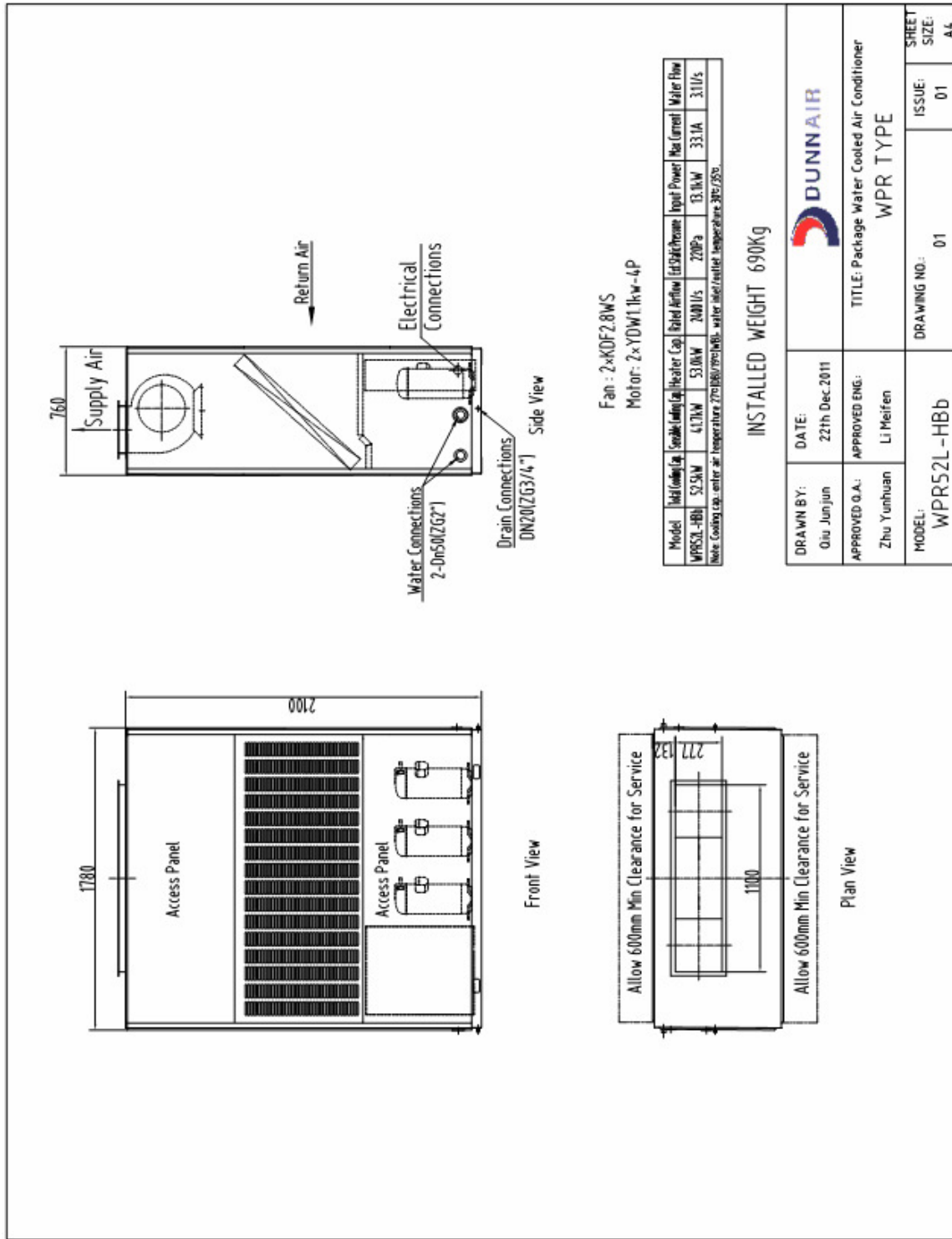

WATER SUPPLY & RETURN

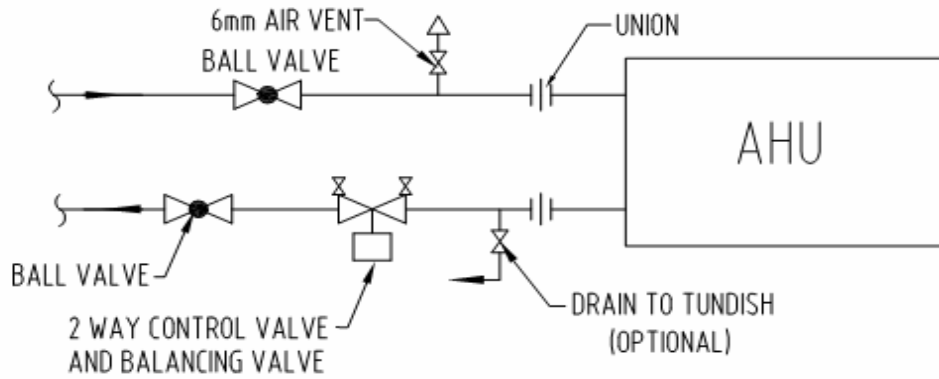

TYP. TWO-WAY VALVE INSTALLATION DETAIL "B"

N.T.S.

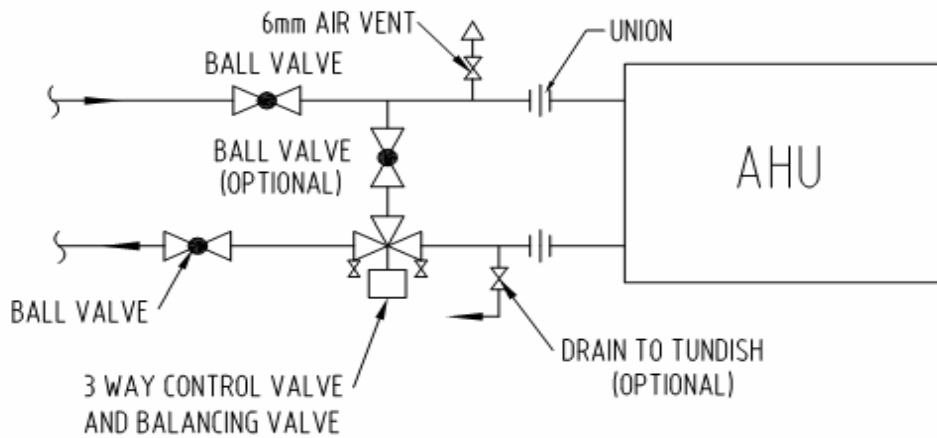

TYP. THREE-WAY VALVE INSTALLATION DETAIL "A"

N.T.S.

CONDENSATE DRAIN

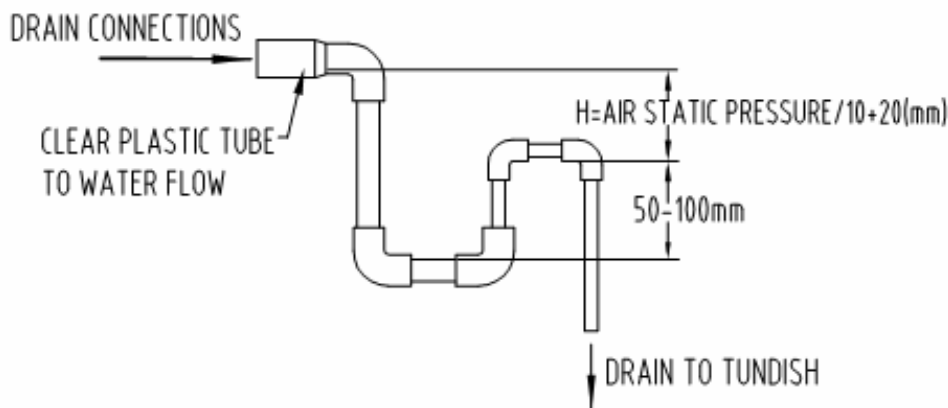

AIR HANDLING PERFORMANCE

Fan Curve (Without Filter)

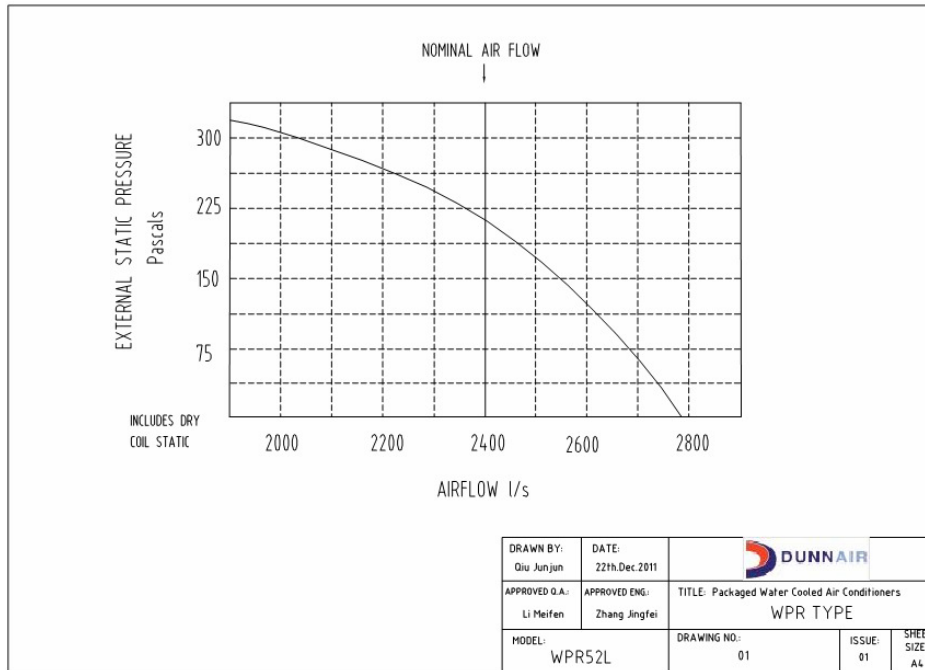

Note:

1. In tropical (high humidity) conditions, care must be taken to select an air flow which gives a suitable coil face air velocity, to prevent water carry over.
2. For applications with low resistance, be sure not to exceed the fan motor full load Amps.
3. Applications using full or high proportions of fresh air should be referred to DUNNAIR engineering office to establish of unit model.
4. EU1 rate filter pressure loss 15Pa.

Sound Levels

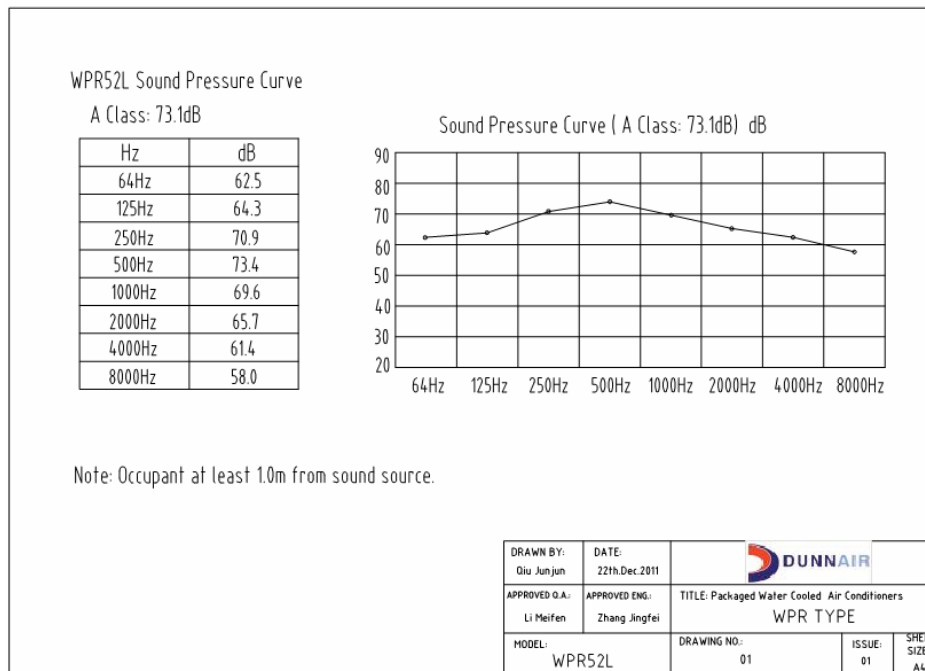

Note: Occupant at least 1.0m from sound source.

WIRING DIAGRAM

