



DUNNAIR
(Aust) Pty Ltd

PHE56

Economy Cycle Rooftop Packaged

R410a Refrigerant

PERFORMANCE DATA

INDOOR COIL ENTERING AIR TEMP °C		OUTDOOR COIL ENTERING TEMPERATURE °C											
		30°C			35°C			40°C			45°C		
		Tot. Cap KW	Sens.Cap KW	LWB °C	Tot. Cap KW	Sens.Cap KW	LWB °C	Tot. Cap KW	Sens.Cap KW	LWB °C	Tot. Cap KW	Sens.Cap KW	LWB °C
DB °C	WB °C												
21	17	54.9	33.6	11.2	51.9	32.4	11.6	49.0	31.2	11.9	46.6	31.2	12.2
	18	56.7	30.1	12.3	53.7	29.0	12.6	50.7	27.8	12.9	48.4	26.9	13.2
	19	58.6	26.6	13.4	55.6	25.4	13.7	52.5	24.1	14.1	50.2	23.2	14.3
	20	60.6	23.3	14.4	57.6	22.2	14.7	54.4	21.0	15.0	52.2	20.1	15.3
23	17	55.0	40.1	11.2	52.1	38.9	11.5	49.2	37.7	11.9	46.8	36.7	12.1
	18	56.6	36.5	12.2	53.7	35.4	12.6	50.7	34.2	12.9	48.3	33.3	13.2
	19	58.5	33.0	13.4	55.5	31.8	13.7	52.5	30.5	14.0	50.2	29.6	14.3
	20	60.6	29.7	14.4	57.5	28.6	14.7	54.4	27.4	15.0	52.2	26.5	15.3
	21	62.7	25.9	15.5	59.6	24.7	15.8	56.4	23.5	16.1	54.3	22.7	16.3
25	17	55.4	45.3	11.1	52.6	43.9	11.5	49.8	42.5	11.8	47.5	41.4	12.1
	18	56.4	44.3	12.1	53.4	41.9	12.5	50.4	40.8	12.8	48.0	39.9	13.0
	19	57.1	43.6	13.0	53.9	39.8	13.3	50.7	38.8	13.5	48.2	38.0	13.7
	20	57.7	43.0	13.7	54.4	37.8	13.9	51.1	36.9	14.2	48.5	36.3	14.3
	21	58.0	42.7	14.3	54.6	35.4	14.6	51.2	34.7	14.8	48.6	34.1	14.9
27	17	56.2	50.7	11.0	53.1	48.5	11.4	50.9	47.3	11.7	49.0	46.0	11.9
	18	57.2	48.6	12.2	54.0	46.7	12.5	51.5	45.9	12.8	50.0	44.9	13.1
	19	58.6	46.2	13.2	55.1	44.5	13.5	52.6	43.8	13.9	51.0	42.9	14.1
	20	60.5	42.6	14.3	57.0	41.0	14.7	54.3	40.2	15.0	52.1	39.4	15.2
	21	62.6	38.8	15.4	59.1	37.1	15.7	56.2	36.4	16.1	54.1	35.6	16.3
29	17	57.2	55.8	10.9	54.7	53.6	11.2	52.2	51.4	11.5	50.3	50.3	11.7
	18	58.2	53.7	12.0	55.5	52.0	12.3	52.7	50.3	12.7	50.3	50.3	12.9
	19	59.0	52.0	13.1	56.1	50.7	13.5	53.1	49.4	13.8	50.9	48.4	14.0
	20	60.6	48.8	14.3	57.5	47.6	14.6	54.4	46.4	14.9	52.2	45.5	15.2
	21	62.6	45.5	15.4	59.5	44.4	15.7	56.3	43.2	16.1	54.2	42.5	16.3
31	17	59.0	59.0	10.7	56.6	56.6	10.9	54.1	54.1	11.3	52.4	52.4	11.5
	18	59.5	58.0	11.9	56.9	55.9	12.2	54.1	54.1	12.5	52.4	52.4	12.7
	19	60.2	56.5	13.0	57.4	54.9	13.3	54.1	54.1	13.6	52.8	52.1	13.9
	20	61.0	55.4	14.3	58.0	54.2	14.6	54.9	53.0	14.9	52.9	52.9	15.1
	21	62.6	52.2	15.3	59.6	51.2	15.6	56.3	50.0	15.9	54.3	49.3	16.2

Capacity multipliers should be applied to the above capacities to adjust for reduced or increased air flow.



Technical Specification PHE56 Economy Cycle Rooftop Packaged Model

Total Cooling Capacity (kW)*	55.1	Number of Compressors	2
Sensible Cooling Capacity (kW)*	44.5	Power Requirements (Volt /Phase)	415 / 3
Heating Capacity (kW)**	55.6	Normal Max. Current (Amps /Phase)	47.7
Nominal Evaporator Air Flow (L/S)	3000	Power Input (kW)	21.9
*Entering air @ 27/19 °C and ambient 35°C		** Entering air @ 21 °C DB and 7°C ambient	

Cooling Performance Correction

Capacity	% Rated Air Quantity - Nominal 3000 l/s				
	80	90	100	110	120
Total Cooling	0.95	0.98	1.00	1.02	1.04
Sensible Cooling	0.89	0.95	1.00	1.05	1.09

Heating Performance Data

Outdoor Coil Entering DB temperature °C					
	0	4	8	12	18
Heating Capacity (kW)	46.5	51.4	59.4	65.3	78.2

Heating Performance Correction

% Rated Air Quantity	Multiplier	Return Air Temp °C	Multiplier	Outdoor Air Temp °C	Approx. Defrost Factor
80	0.93	15	1.05	0	0.80
90	0.97	18	1.03	2	0.78
100	1.00	21	1.00	4 - 6	0.75
110	1.03	24	0.97	7	0.87
120	1.05	27	0.95	8	1.00

Compressor

Number Per Unit	2
Type	Scroll
RPM (Nom)	2900
Normal Max Current (Amps /Phase)	2 x 18.0
Locked Rotor Current (Amps /Phase)	2 x 96
Displacement (m ³ /h)	2 x 17.6

Electrical Controls and Safeties

High Pressure Switch (Setting kPa)	4000	Defrost	
Low Pressure Switch (Setting kPa)	300	Initiation Temperature (°C)	-2
Indoor Fan Overload	Internal	Termination Temperature (°C)	18
Outdoor Fan Overload	Internal	Min. Period Between De-Ice (min)	30
Compressor Delay Timer	300 sec	Max De-Ice Period (min)	10

Standard Features

Auto reset high pressure and auto reset low pressure cutouts	
Thermal overload protection on all motors	Suction line accumulator
Compressor crankcase heater	Automatic de-ice system
Limit start timer (anti short cycling)	Thermally insulated indoor unit

Evaporator Coil

Type	Copper Tube / Aluminium Fins
Face Area (m ²)	2 x 0.6
Air Quantity (l/s)	3000

Evaporator Fan

Number of Fans	1
Type	Centrifugal
Drive	Belt
Motor Voltage /Phase /Frequency	415 /3 /50
Motor Power (kW)	4.0
Maximum Fan Speed (rpm)	870

Electrical

Power Requirements	3 Phase /415V /50Hz
Normal Max. Current (Amps /Phase)	47.7

Condenser Coil

Type	Copper Tube /Aluminium Fins
Face Area(m ²)	2 x 1.03

Condenser Fan

Number of Fans	4
Type	Axial
Drive	Direct
Motor Type	Enclosed
Motor Watts /rpm	4 x 180 / 950
Motor Voltage /Phase /Frequency	415 / 3 / 50

Refrigeration System

Refrigerant Type	R410A
Charge(kg)	2 x 7.4
Service Connections	Rotor Lock Valves
Expansion Control - In / Outdoor unit	TX Valve

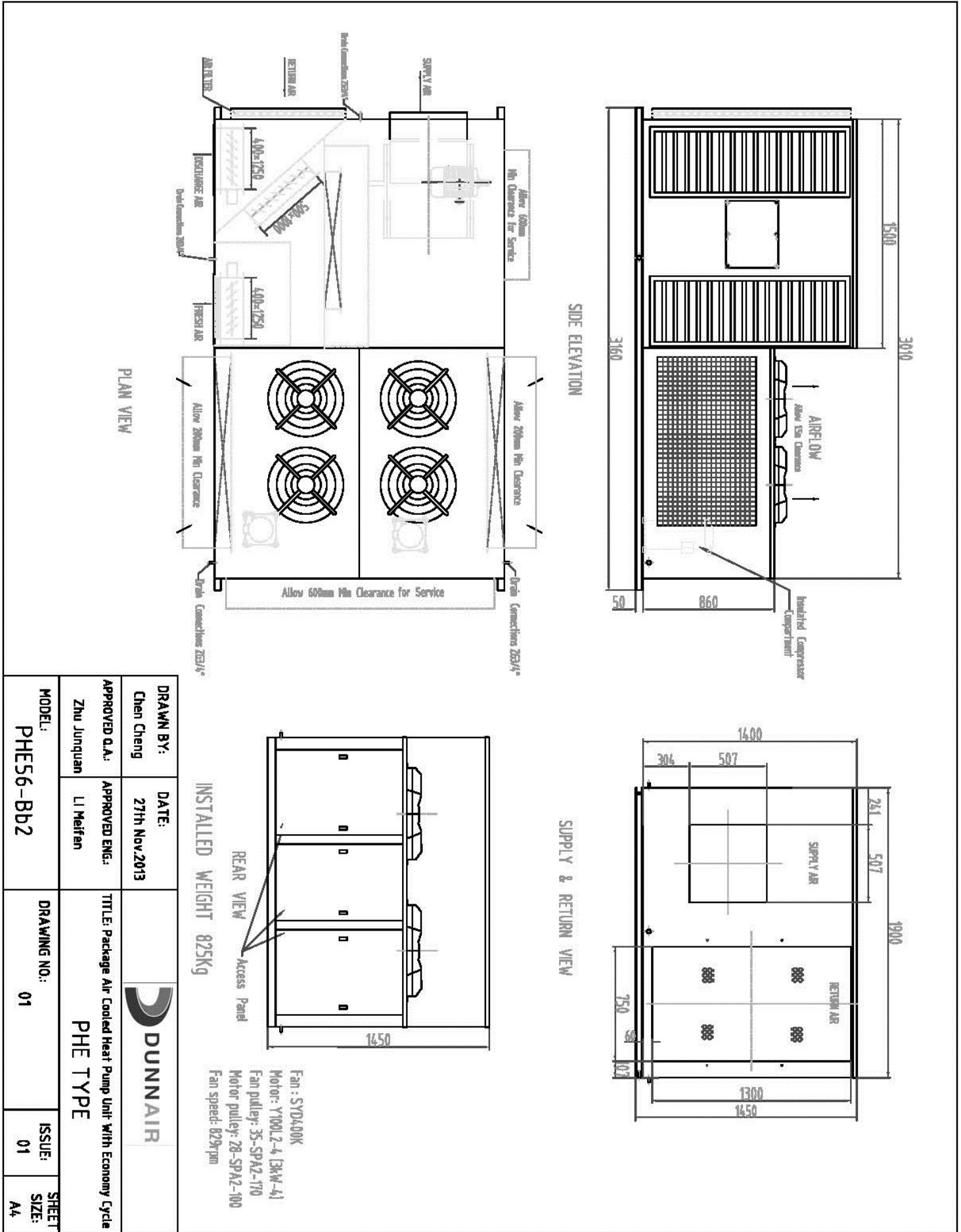

DRAWN BY: Chen Cheng	DATE: 27th Nov.2013	
APPROVED Q.A.: Zhu Junquan	APPROVED ENG.: Li Meifen	
MODEL: PHE56-Bb2		TITLE: Package Air Cooled Heat Pump Unit with Economy Cycle
DRAWING NO.: 01		PHE TYPE
ISSUE: 01	SHEET SIZE: A4	

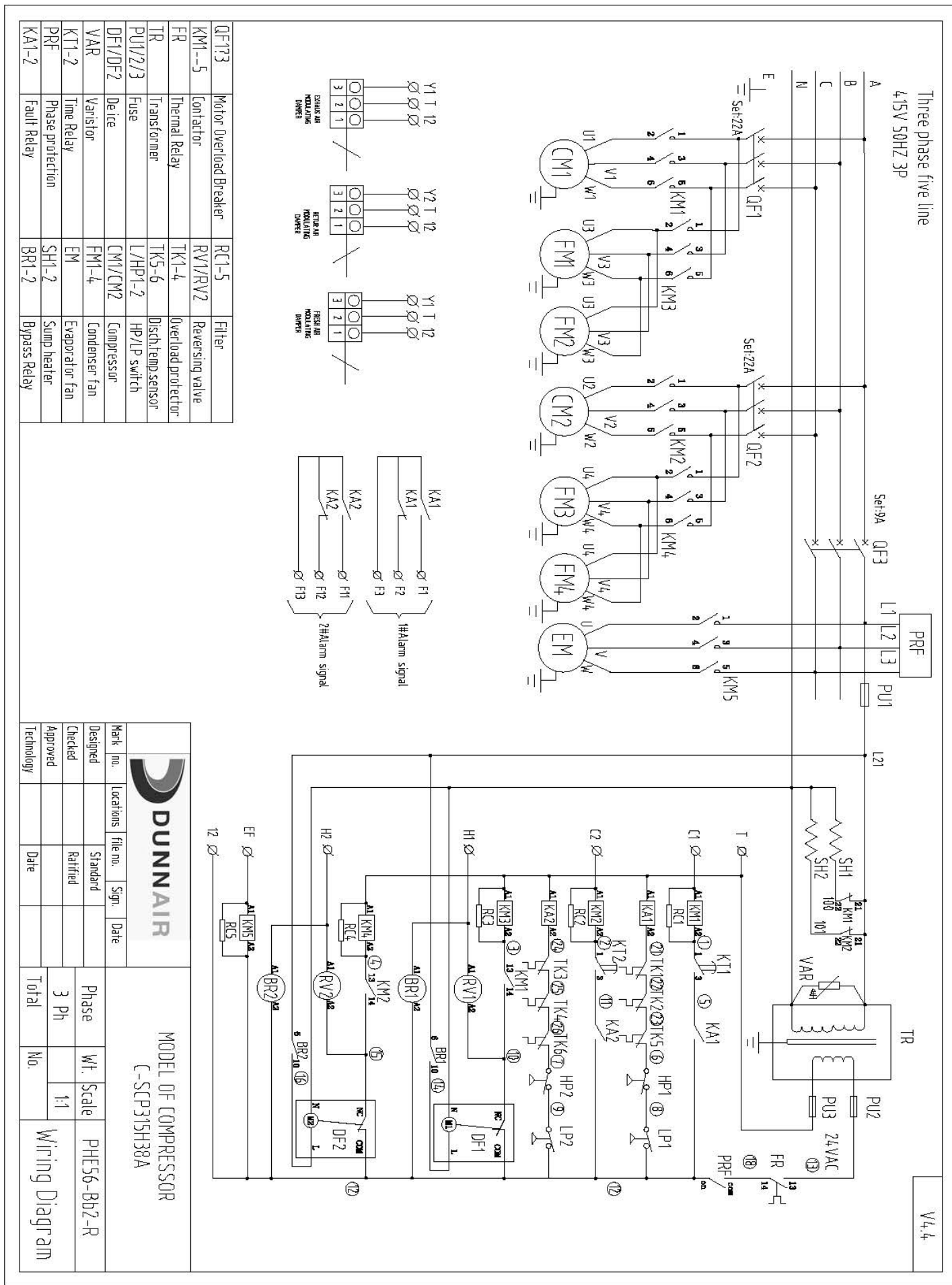

QF1/3	Motor Overload Breaker	RC1-5	Filter
KM1-5	Contactors	RV1/RV2	Reversing valve
FR	Thermal Relay	TK1-4	Overload protector
TR	Transformer	TK5-6	Disch temp sensor
PU1/2/3	Fuse	L/HP1-2	HP/LP switch
DF1/DF2	Deice	CM1/CM2	Compressor
VAR	Varistor	FM1-4	Condenser fan
KT1-2	Time Relay	EM	Evaporator fan
PRF	Phase protection	SH1-2	Sump heater
KA1-2	Fault Relay	BR1-2	Bypass Relay

		MODEL OF COMPRESSOR C-SCP315H38A	
		Phase	Wt. Scale
Mark	Inn.	Locations	file nu.
Designed		Standard	Sign.
Checked		Ratified	Date
Approved			
Technology			
Total		No.	

Wiring Diagram

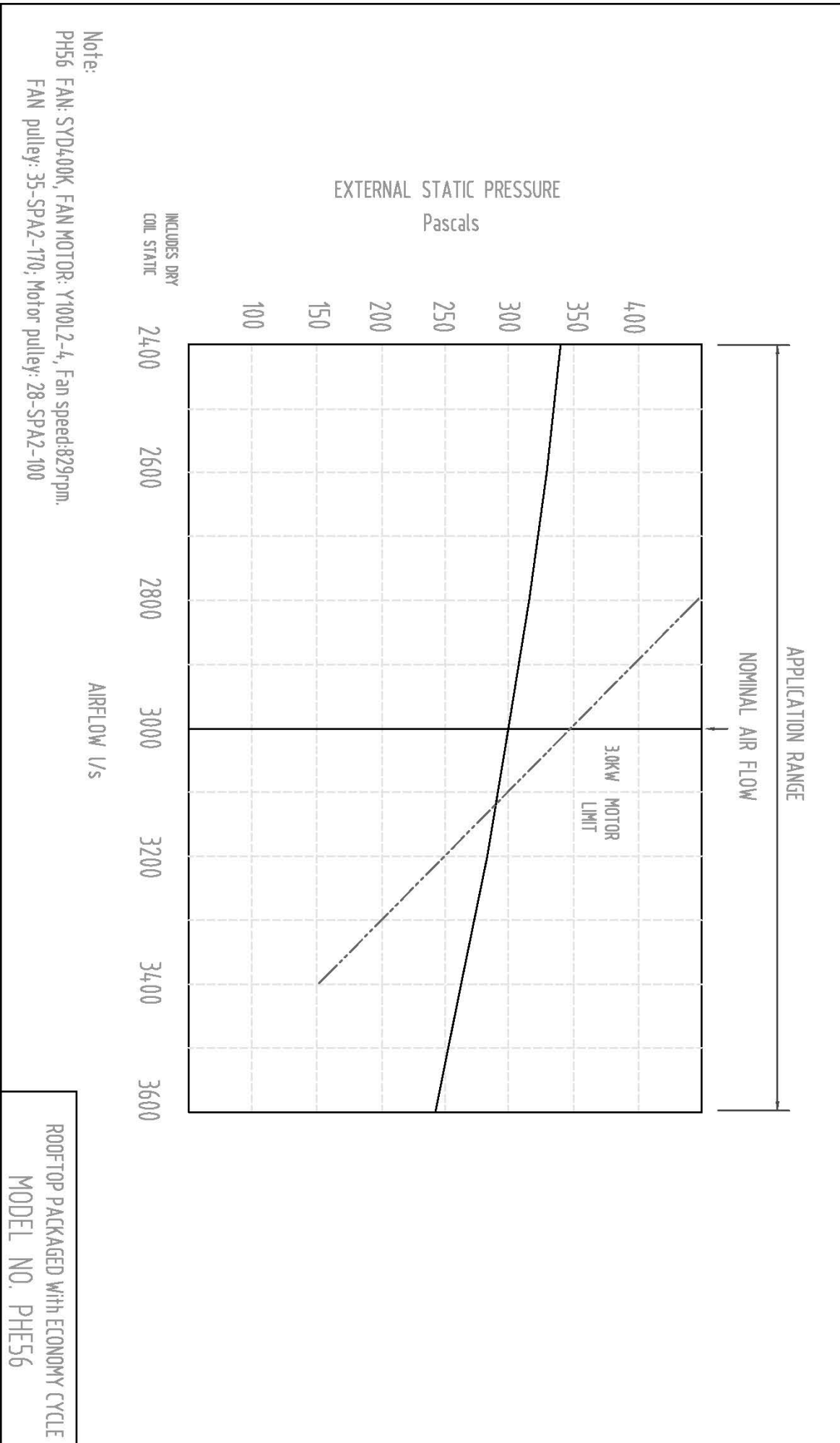

PHE56 Sound Pressure Curve

A Class: 72.3dB

Hz	dB
64Hz	44
125Hz	59
250Hz	58
500Hz	65
1000Hz	68
2000Hz	66
4000Hz	64
8000Hz	58

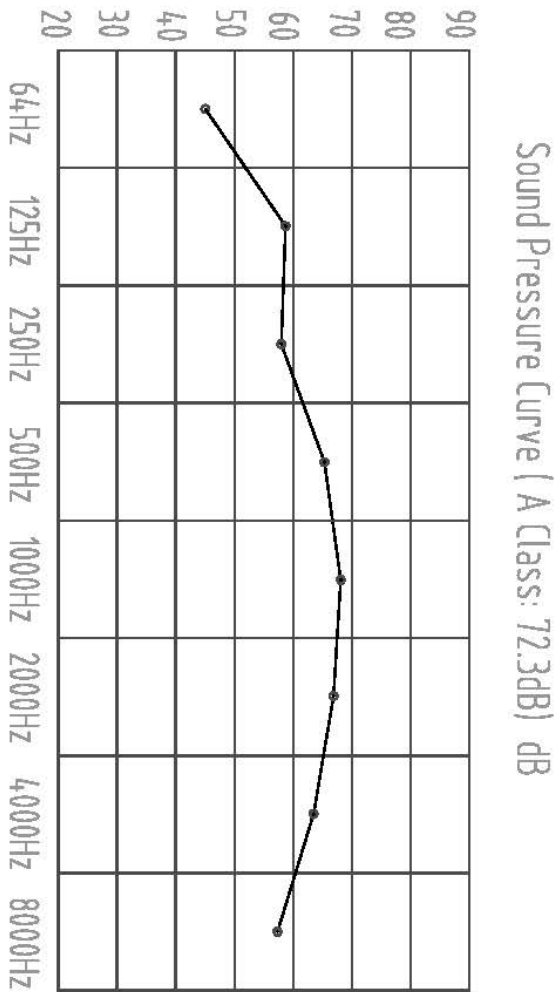

Note: Occupant at least 1.0m from sound source.

DRAWN BY: Chen Cheng	DATE: 13th. Feb. 2014		
APPROVED O.A.: Zhu Junquan	APPROVED ENG.: Li Meifen		
TITLE: Packaged Rooftop With Economy Cycle		PHE TYPE	
MODEL: PHE56	DRAWING NO.: 01		