



**DUNNAIR**  
(Aust) Pty Ltd

**PHE120**

*Economy Cycle Rooftop Packaged*

R410A Refrigerant

**PERFORMANCE DATA**

INDOOR COIL ENTERING AIR TEMP °C		OUTDOOR COIL ENTERING TEMPERATURE °C											
		30°C			35°C			40°C			45°C		
		Tot. Cap KW	Sens.Cap KW	LWB °C	Tot. Cap KW	Sens.Cap KW	LWB °C	Tot. Cap KW	Sens.Cap KW	LWB °C	Tot. Cap KW	Sens.Cap KW	LWB °C
DB °C	WB °C												
21	17	115.3	70.7	11.5	109.3	68.2	11.8	103.1	65.5	12.2	98.3	65.5	12.4
	18	119.3	63.8	12.1	113.2	61.2	13.0	106.6	58.3	13.3	102.4	56.5	13.6
	19	123.7	56.5	13.9	117.2	53.9	14.2	110.2	51.0	14.6	106.3	49.5	14.8
	20	128.1	49.0	14.8	1215.0	46.3	15.3	114.3	43.4	15.7	110.2	41.6	16.0
23	17	115.8	84.5	11.4	109.7	82.1	11.8	103.5	79.4	12.1	99.1	77.5	12.4
	18	119.3	77.4	12.5	113.2	74.8	12.8	106.6	71.9	13.3	102.4	70.2	13.6
	19	123.7	70.2	13.7	117.3	67.6	14.1	110.3	64.9	14.5	106.3	63.1	14.8
	20	128.2	62.6	14.8	121.5	59.9	15.3	114.4	57	15.7	110.3	55.3	15.9
	21	132.8	55.1	15.9	126.1	52.4	16.3	118.4	49.3	16.7	114.4	47.5	17.1
25	17	117.0	97.2	11.3	110.8	94.4	11.6	104.6	91.6	12.1	100.6	89.6	12.3
	18	119.6	94.0	12.6	113.5	89.1	13.0	106.9	86.2	13.4	102.7	84.5	13.7
	19	123.9	89.4	13.7	117.3	81.3	14.1	110.3	78.6	14.5	106.5	76.8	14.7
	20	128.2	84.4	14.8	121.6	73.7	15.3	114.4	70.7	15.7	110.3	69.0	15.9
	21	132.9	78.7	15.9	126.1	61.4	16.3	118.4	62.9	16.7	114.4	61.4	17.0
27	17	118.7	107.7	11.2	113.3	104.5	11.5	107.2	100.9	11.9	103.4	98.6	12.2
	18	121.1	105.4	12.4	114.7	102.8	12.7	108.1	99.8	13.2	104.9	98.1	13.4
	19	124.8	97.8	13.5	117.6	95.2	13.9	110.6	92.3	14.3	106.6	90.6	14.5
	20	128.3	90.9	14.7	121.6	88.2	15.1	114.4	85.4	15.5	110.3	83.7	15.7
	21	132.9	82.4	15.9	126.2	79.7	16.3	118.5	76.6	16.7	114.5	75.0	17.0
29	17	121.9	111.4	11.1	116.4	112.9	11.5	110.3	108.4	11.9	105.8	105.8	12.1
	18	123.1	109.5	12.3	117.1	111.2	12.7	110.6	107.7	13.2	106.6	102.9	13.4
	19	124.8	107.6	13.6	118.5	109.5	13.9	111.6	106.9	14.3	107.0	100.9	14.6
	20	128.3	104.2	14.7	121.8	101.5	15.1	114.5	98.3	15.6	110.4	96.8	15.8
	21	132.9	95.2	15.9	126.2	93.2	16.3	118.5	90.2	16.7	114.5	88.7	17.0
31	17	125.9	124.5	10.7	120.5	119.6	11.1	114.1	114.1	11.5	110.5	110.5	11.7
	18	126.5	123.1	12.1	120.7	119.1	12.4	114.5	113.9	12.8	111.2	110.5	13.2
	19	127.1	121.7	13.4	121.1	118.7	13.8	114.5	113.3	14.2	111.2	110.1	14.4
	20	129.2	118.5	14.6	122.8	115.9	15.1	115.5	111.9	15.5	111.4	109.9	15.8
	21	133.1	110.6	15.9	126.3	108.0	16.3	118.7	109.5	16.7	114.7	103.3	17.1

Capacity multipliers should be applied to the above capacities to adjust for reduced or increased air flow.



## Technical Specification PH120 Rooftop Packaged Model

Total Cooling Capacity (kW)*	117.6	Number of Compressors	2
Sensible Cooling Capacity (kW)*	95.2	Power Requirements (Volt /Phase)	415 / 3
Heating Capacity (kW)**	116.2	Normal Max. Current (Amps /Phase)	98.8
Nominal Evaporator Air Flow (L/S)	6500	Power Input (kW)	46.8
*Entering air @ 27/19 °C and ambient 35°C		** Entering air @ 21 °C DB and 7°C ambient	

### Cooling Performance Correction

Capacity	% Rated Air Quantity - Nominal 6500 l/s				
	80	90	100	110	120
Total Cooling	0.95	0.98	1.00	1.02	1.04
Sensible Cooling	0.89	0.95	1.00	1.05	1.09

### Heating Performance Data

Outdoor Coil Entering DB temperature °C					
	0	4	8	12	18
Heating Capacity (kW)	91.2	100.7	116.6	128.1	154.1
Heating cap. Is based on 21 °C DB. Frost formation will have greatest effect at amb. 4-6 °C. Above 8 °C defrost is unlikely & a factor of 1 may be used.					

### Heating Performance Correction

% Rated Air Quantity	Multiplier	Return Air Temp °C	Multiplier	Outdoor Air Temp °C	Approx. Defrost Factor
80	0.93	15	1.05	0	0.80
90	0.97	18	1.03	2	0.78
100	1.00	21	1.00	4 - 6	0.75
110	1.03	24	0.97	7	0.87
120	1.05	27	0.95	8	1.00

### Compressor

Number Per Unit	2
Type	Hermetic Scroll
RPM (Nom)	2900
Normal Max Current (Amps /Phase)	2 x 37.8
Locked Rotor Current (Amps /Phase)	2 x 215
Displacement (m³/h)	2 x 39.6

### Electrical Controls and Safeties

High Pressure Switch (Setting kPa)	4000	Defrost	
Low Pressure Switch (Setting kPa)	300	Initiation Temperature (°C)	-2
Indoor Fan Overload	Internal	Termination Temperature (°C)	18
Outdoor Fan Overload	Internal	Min. Period Between De-Ice (min)	30
Compressor Delay Timer	300 sec	Max De-Ice Period (min)	10

### Standard Features

Auto reset high pressure and low pressure cutouts	
Thermal overload protection on all motors	Suction line accumulator
Compressor crankcase heater	Automatic de-ice system
Limit start timer (anti short cycling)	25 mm insulation to indoor unit
240 Volt Control	Sight Glass

### Evaporator (Coil)

Type	Copper Tube / Aluminium Fins
Face Area (m²)	2.62
Air Quantity (l/s)	6500

### Evaporator (Fan Motor) #

Number of Fans	1
Type	Centrifugal
Drive	Belt
Motor Voltage /Phase /Frequency	415 /3 /50
Motor Power (kW)	7.5
Maximum Fan Speed (rpm)	620

### Electrical

Power Requirements	3 Phase /415V /50Hz
Normal Max. Current (Amps /Phase)	98.8

### Condenser (Coil)

Type	Copper Tube /Aluminium Fins
Face Area(m²)	2 x 1.84

### Condenser (Fan Motor)

Number of Fans	4
Type	Axial
Drive	Direct
Motor Type	Enclosed
Motor Power (kW)	4 x 0.55
Motor Voltage /Phase /Frequency	415 / 3 / 50

### Refrigeration System

Refrigerant Type	R410A
Charge(kg)	2 x 14.6
Service Connections	Rotor Lock Valves
Expansion Control - In / Outdoor unit	TX Valve

# Evaporator unit is supplied with a variable speed motor pulley.



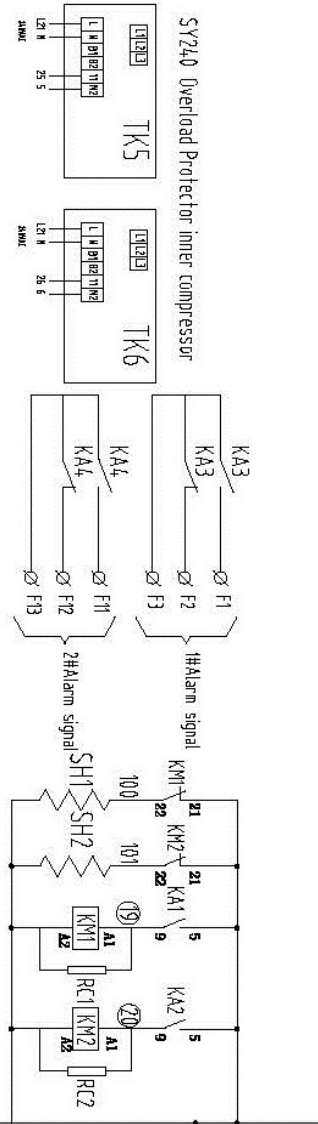
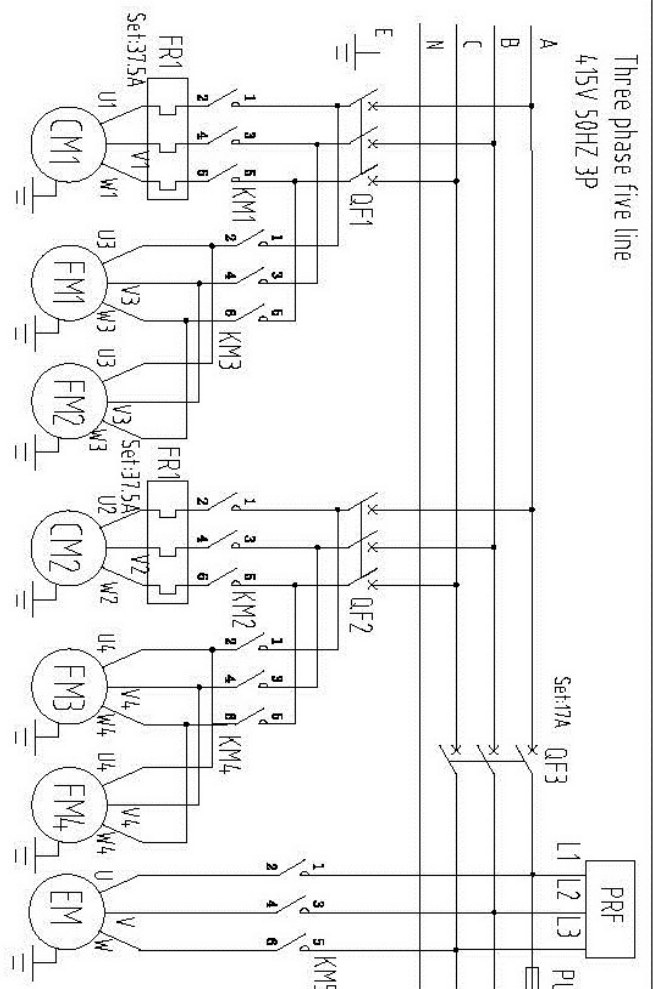

QF1/3	Motor Overload Breaker	RC1-5	Filter
KM1-5	Contactor	RV1/RV2	Reversing valve
FR	Thermal Relay	TK1-4	Overload protector
TR	Transformer	L/HP1-2	HP/LP switch
PU1/2/3	Fuse	CM1/CM2	Compressor
DF1/DF2	Device	FM1-4	Condenser fan
VAR	Varistor	EM	Evaporator fan
K11-2	Time Relay	SH1-2	Sump heater
PRF	Phase protection	BR1-2	Bypass Relay
KA1-2	Intermediate relay	TK5-6	Compressor protect
KA3-4	Fault Relay		

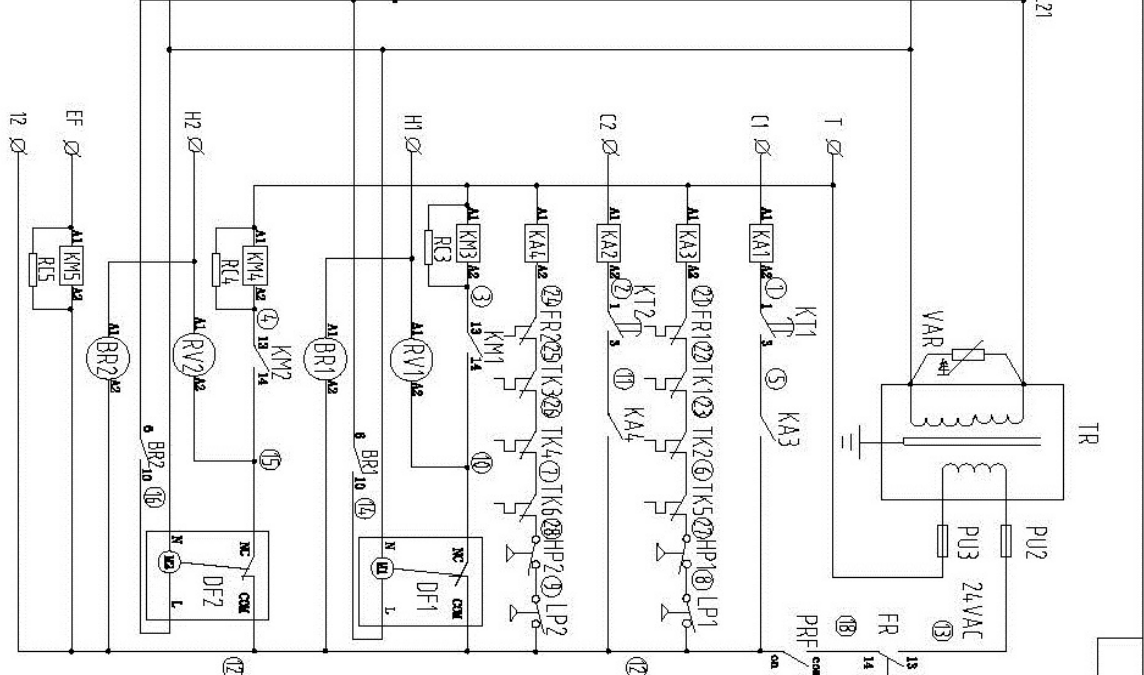
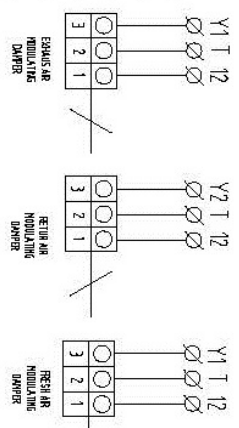

**MODEL OF COMPRESSOR**  
SY240-4

Mark	no.	Locations	file no.	Sign.	Date
Designed					
Checked					
Approved					
Technology					

Phase	3 Ph	Wt. Scale	PHE120-Bb2-R
Total	No.	Wiring Diagram	

V4.4

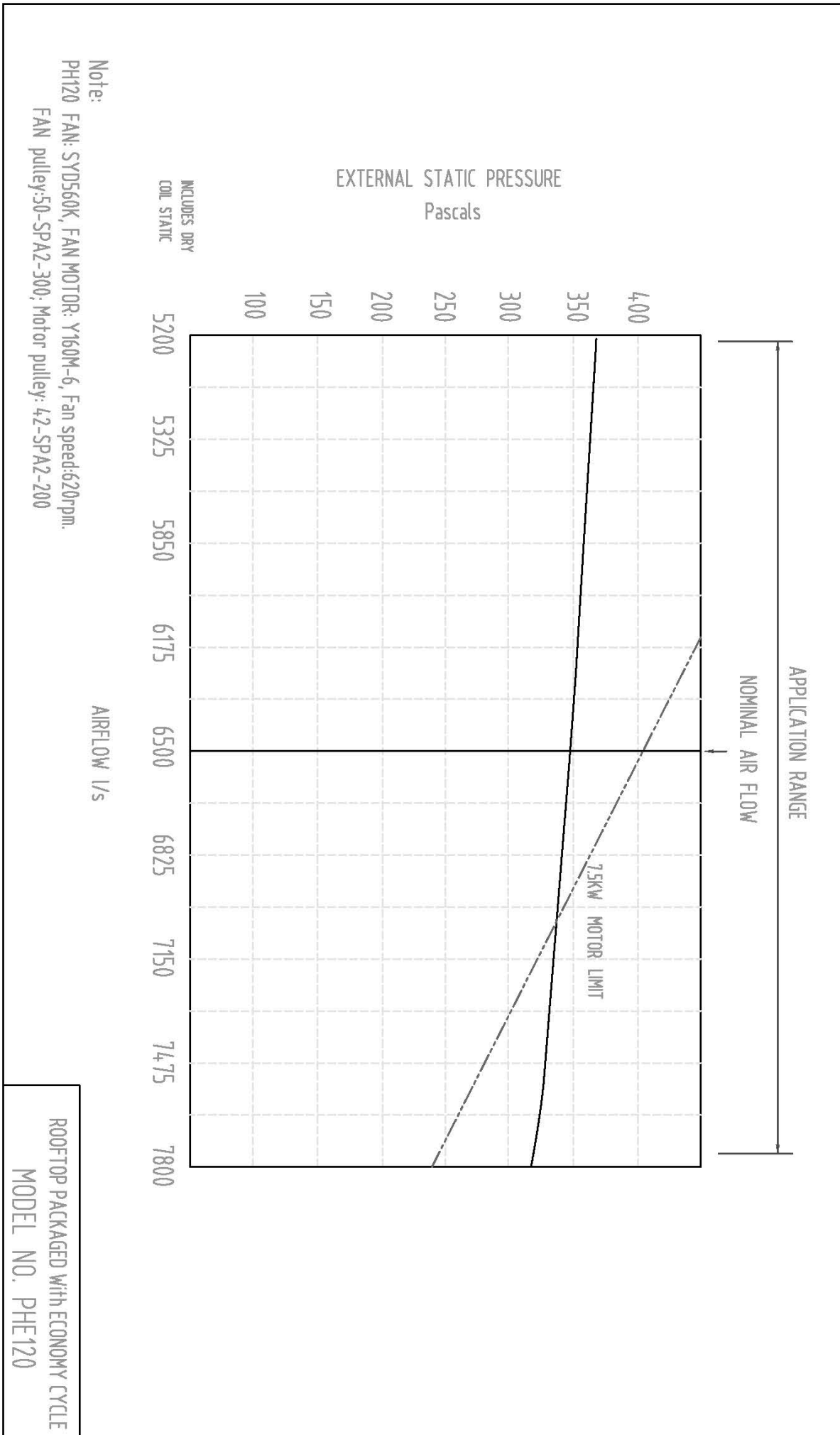

PHE120 Sound Pressure Curve

A Class: 76.0dB

Hz	dB
64Hz	49
125Hz	61
250Hz	63
500Hz	72
1000Hz	70
2000Hz	70
4000Hz	68
8000Hz	61

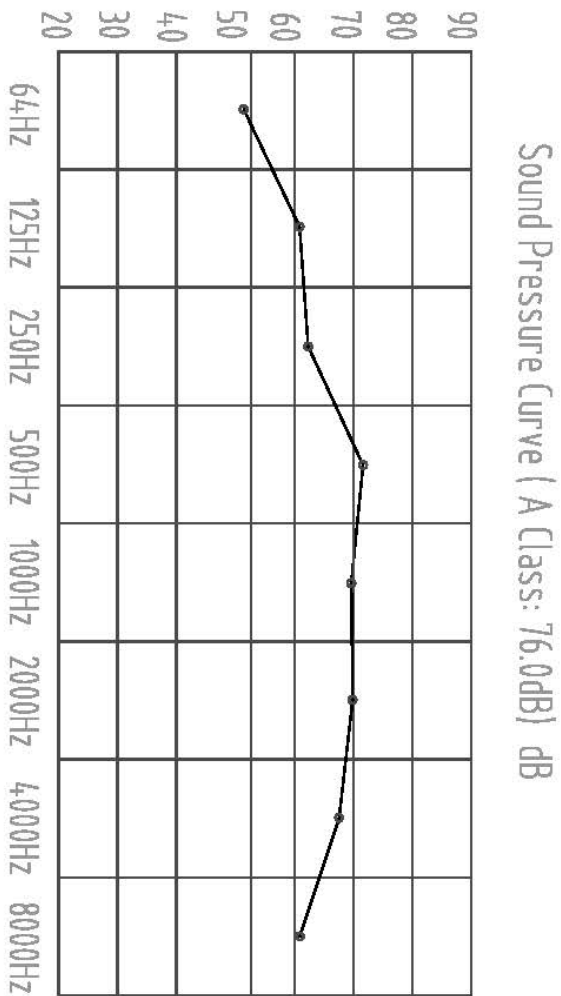

Note: Occupant at least 1.0m from sound source.

<b>DRAWN BY:</b> Chen Cheng	<b>DATE:</b> 13th, Feb, 2014	
<b>APPROVED O.A.:</b> Zhu Junquan	<b>APPROVED ENG.:</b> Li Meifen	
<b>TITLE:</b> Packaged Rooftop With Economy Cycle <b>PHE TYPE</b>		
<b>MODEL:</b> PHE120	<b>DRAWING NO.:</b> 01	<b>ISSUE:</b> 01
		<b>SHEET SIZE:</b> A4