



DUNNAIR
(Aust) Pty Ltd

PHE100

Economy Cycle Rooftop Packaged

R410A Refrigerant

PERFORMANCE DATA

INDOOR COIL ENTERING AIR TEMP °C		OUTDOOR COIL ENTERING TEMPERATURE °C											
		30°C			35°C			40°C			45°C		
		Tot. Cap KW	Sens. Cap KW	LWB °C	Tot. Cap KW	Sens. Cap KW	LWB °C	Tot. Cap KW	Sens. Cap KW	LWB °C	Tot. Cap KW	Sens. Cap KW	LWB °C
DB °C	WB °C												
21	17	100.4	61.6	11.5	95.2	59.4	11.8	89.7	57.2	12.2	85.9	57.2	12.4
	18	103.9	55.6	12.1	98.6	53.4	13.0	92.8	50.9	13.3	89.2	49.3	13.6
	19	107.3	49.3	13.9	102.1	47.1	14.2	95.8	44.5	14.6	92.5	43.1	14.8
	20	111.7	42.7	14.8	105.8	40.3	15.3	99.5	37.8	15.7	95.8	36.3	16.0
23	17	100.8	73.6	11.4	95.6	71.6	11.8	90.1	69.2	12.1	86.3	67.7	12.4
	18	103.9	67.5	12.5	98.6	65.3	12.8	92.8	62.7	13.3	89.2	61.2	13.6
	19	107.3	61.2	13.7	102.1	59	14.1	96	56.5	14.5	92.5	55	14.8
	20	111.7	54.6	14.8	105.8	52.2	15.3	99.5	49.7	15.7	96	48.2	15.9
	21	115.8	48.1	15.9	109.6	45.6	16.3	103.4	43	16.7	99.5	41.4	17.1
25	17	101.8	84.7	11.3	96.6	82.3	11.6	91.2	79.8	12.1	87.7	78.2	12.3
	18	104.2	81.9	12.6	98.9	77.7	13.0	93.1	75.2	13.4	89.4	73.6	13.7
	19	107.5	78.0	13.7	102.1	70.9	14.1	96.0	68.5	14.5	92.4	67.0	14.7
	20	111.7	73.5	14.8	105.9	64.3	15.3	99.6	61.6	15.7	96.0	60.3	15.9
	21	115.8	68.6	15.9	109.6	53.6	16.3	103.4	54.9	16.7	99.5	53.6	17.0
27	17	103.4	93.9	11.2	96.7	91.2	11.5	93.4	88.0	11.9	90.0	86.0	12.2
	18	105.5	91.9	12.4	99.8	89.6	12.7	94.0	87.1	13.2	91.5	85.6	13.4
	19	108.7	85.3	13.5	102.4	82.9	13.9	96.3	80.5	14.3	92.8	79.0	14.5
	20	111.8	79.2	14.7	105.9	76.8	15.1	99.6	74.4	15.5	96.0	72.9	15.7
	21	115.8	71.8	15.9	109.8	69.4	16.3	103.4	66.7	16.7	99.7	65.4	17.0
29	17	106.2	97.1	11.1	101.4	98.5	11.5	96.0	94.6	11.9	92.2	92.2	12.1
	18	107.1	95.5	12.3	102.0	96.9	12.7	96.3	93.9	13.2	92.8	89.6	13.4
	19	108.7	93.8	13.6	103.2	95.8	13.9	97.1	93.2	14.3	93.2	88.0	14.6
	20	111.8	90.8	14.7	106.0	88.5	15.1	99.7	85.7	15.6	96.2	84.5	15.8
	21	115.8	83.7	15.9	109.8	81.4	16.3	103.4	78.7	16.7	99.7	77.3	17.0
31	17	109.6	108.6	10.7	105.0	104.3	11.1	99.3	99.3	11.5	96.2	96.2	11.7
	18	110.1	107.2	12.1	105.1	103.9	12.4	99.7	99.3	12.8	96.7	96.1	13.2
	19	110.7	106.2	13.4	105.5	103.5	13.8	99.7	98.8	14.2	96.7	96.1	14.4
	20	112.5	103.3	14.6	106.9	101.0	15.1	100.5	97.5	15.5	97.0	95.8	15.8
	21	115.9	96.5	15.9	110.0	94.1	16.3	103.4	95.5	16.7	99.8	90.0	17.1

Capacity multipliers should be applied to the above capacities to adjust for reduced or increased air flow.



Technical Specification PH100 Rooftop Packaged Model

Total Cooling Capacity (kW)*	102.2	Number of Compressors	2
Sensible Cooling Capacity (kW)*	82.9	Power Requirements (Volt /Phase)	415 / 3
Heating Capacity (kW)**	98.5	Normal Max. Current (Amps /Phase)	85.2
Nominal Evaporator Air Flow (L/S)	5500	Power Input (kW)	40.1
*Entering air @ 27/19 °C and ambient 35°C		** Entering air @ 21 °C DB and 7°C ambient	

Cooling Performance Correction

Capacity	% Rated Air Quantity - Nominal 5500 l/s				
	80	90	100	110	120
Total Cooling	0.95	0.98	1.00	1.02	1.04
Sensible Cooling	0.89	0.95	1.00	1.05	1.09

Heating Performance Data

Outdoor Coil Entering DB temperature °C					
	0	4	8	12	18
Heating Capacity (kW)	77.2	85.2	98.7	108.4	130.4
Heating cap. Is based on 21 °C DB. Frost formation will have greatest effect at amb. 4-6 °C. Above 8 °C defrost is unlikely & a factor of 1 may be used.					

Heating Performance Correction

% Rated Air Quantity	Multiplier	Return Air Temp °C	Multiplier	Outdoor Air Temp °C	Approx. Defrost Factor
80	0.93	15	1.05	0	0.80
90	0.97	18	1.03	2	0.78
100	1.00	21	1.00	4 - 6	0.75
110	1.03	24	0.97	7	0.87
120	1.05	27	0.95	8	1.00

Compressor

Number Per Unit	2
Type	Hermetic Scroll
RPM (Nom)	2900
Normal Max Current (Amps /Phase)	25.1 / 37.8
Locked Rotor Current (Amps /Phase)	158 / 215
Displacement (m ³ /h)	26.4 / 39.6

Electrical Controls and Safeties

High Pressure Switch (Setting kPa)	4000	Defrost	
Low Pressure Switch (Setting kPa)	300	Initiation Temperature (°C)	-2
Indoor Fan Overload	Internal	Termination Temperature (°C)	18
Outdoor Fan Overload	Internal	Min. Period Between De-Ice (min)	30
Compressor Delay Timer	300 sec	Max De-Ice Period (min)	10

Standard Features

Auto reset high pressure and low pressure cutouts	
Thermal overload protection on all motors	Suction line accumulator
Compressor crankcase heater	Automatic de-ice system
Limit start timer (anti short cycling)	25 mm insulation to indoor unit
240 Volt Control	Sight Glass

Evaporator (Coil)

Type	Copper Tube / Aluminium Fins
Face Area (m ²)	2.2
Air Quantity (l/s)	5500

Evaporator (Fan Motor)

Number of Fans	1
Type	Centrifugal
Drive	Belt
Motor Voltage /Phase /Frequency	415 /3 /50
Motor Power (kW)	7.5
Maximum Fan Speed (rpm)	720

Electrical

Power Requirements	3 Phase /415V /50Hz
Normal Max. Current (Amps /Phase)	85.2

Condenser (Coil)

Type	Copper Tube /Aluminium Fins
Face Area(m ²)	2 x 1.84

Condenser (Fan Motor)

Number of Fans	4
Type	Axial
Drive	Direct
Motor Type	Enclosed
Motor Power (kW)	4 x 0.55
Motor Voltage /Phase /Frequency	415 / 3 / 50

Refrigeration System

Refrigerant Type	R410A
Charge(kg)	9.8 / 14.6
Service Connections	Rotor Lock Valves
Expansion Control - In / Outdoor unit	TX Valve

Evaporator unit is supplied with a variable speed motor pulley.

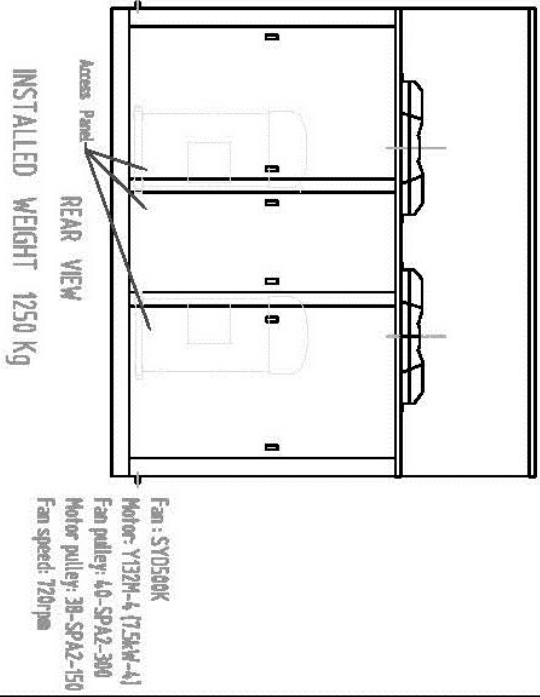
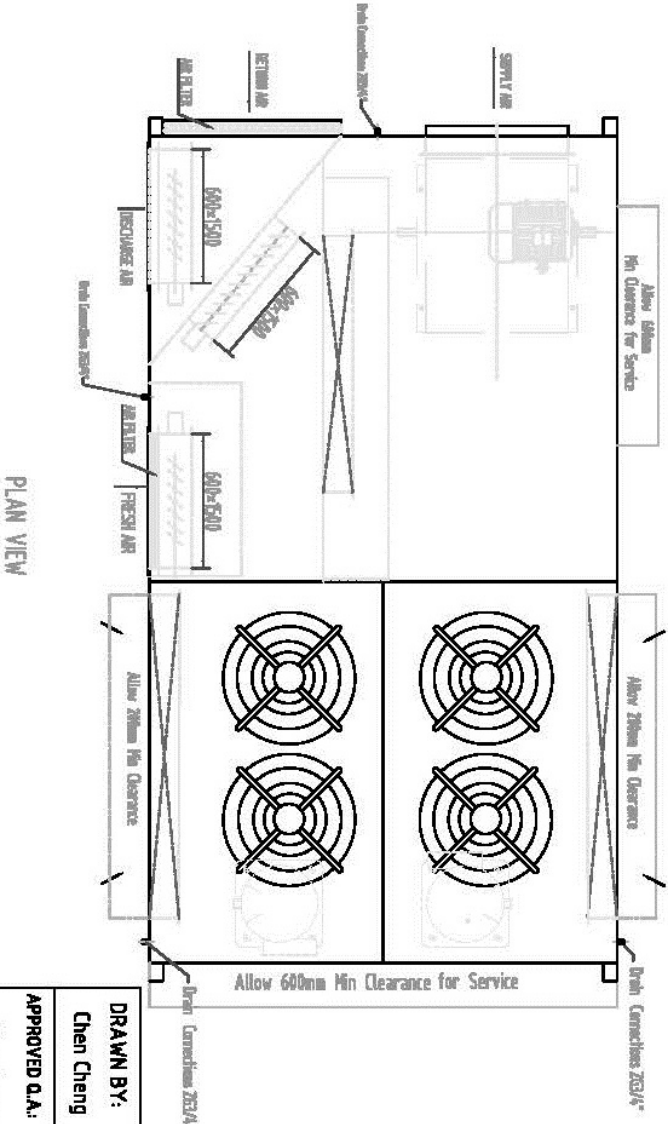
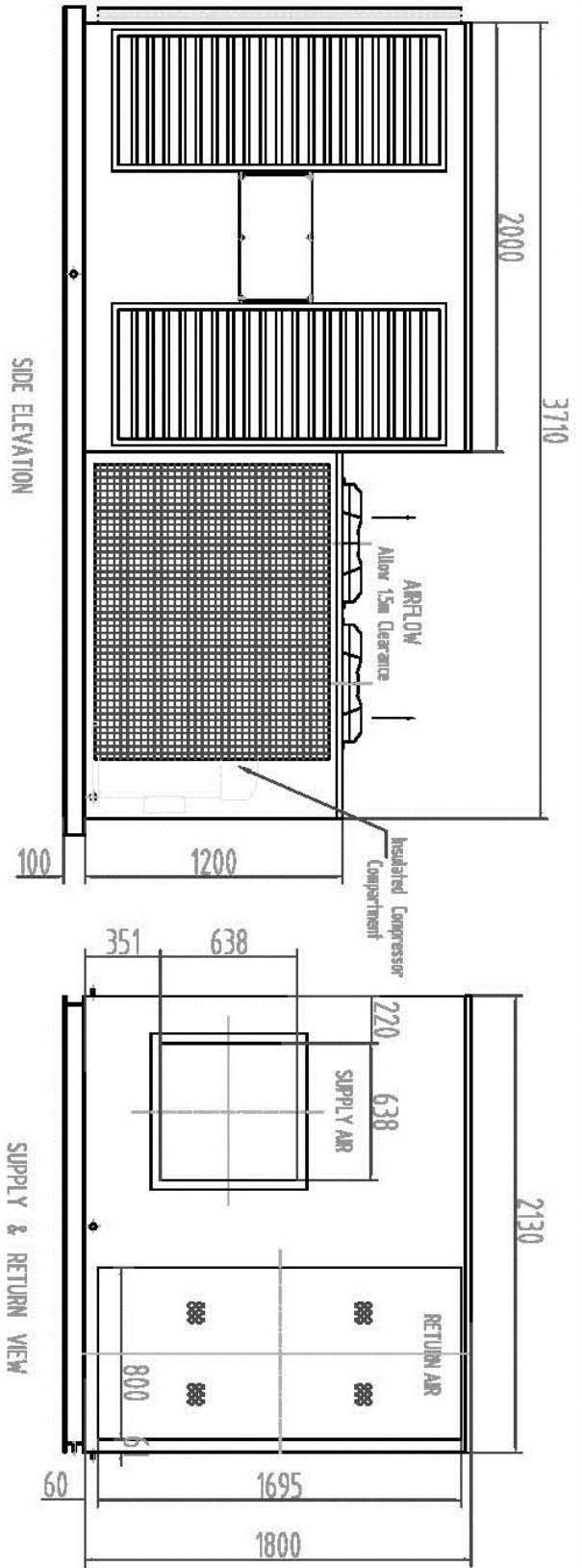

DRAWN BY: Chen Cheng	DATE: 28th Feb.2014	
APPROVED O.A.: Zhu Junquan	APPROVED ENG.: LI Melfan	
TITLE: Package Air Cooled Heat Pump Unit With Economy Cycle		PHE TYPE
MODEL: PHE100-Bb2	DRAWING NO.: 01	
ISSUE: 01	SHEET SIZE: A4	

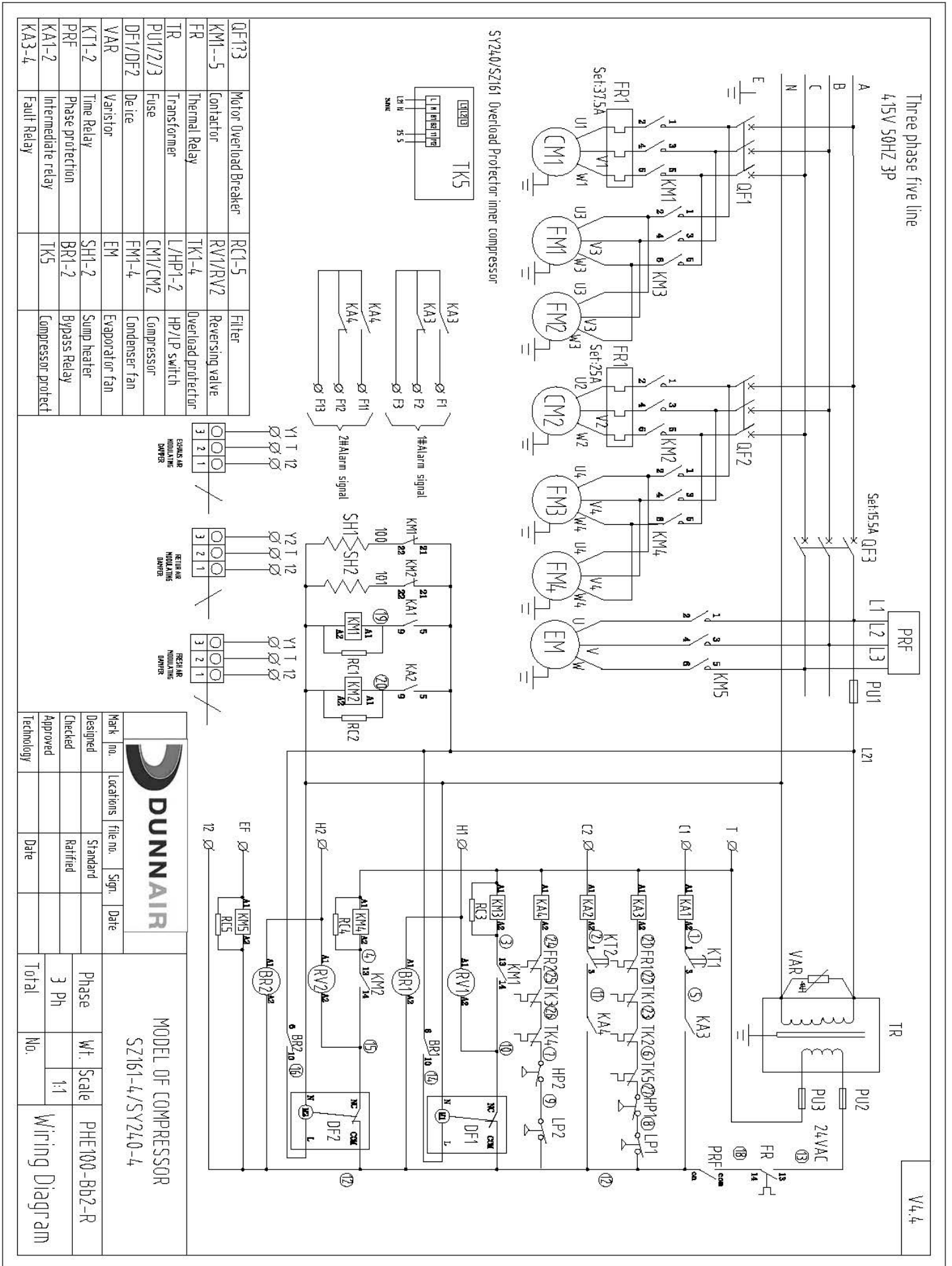

SY240/SZ161 Overload Protector inner compressor

QF1/3	Motor Overload Breaker	RC1-5	Filter
KM1--5	Contactors	RV1/RV2	Reversing valve
FR	Thermal Relay	TK1-4	Overload protector
TR	Transformer	L/HP1-2	HP/LP switch
PU1/2/3	Fuse	CM1/CM2	Compressor
DF1/DF2	Device	FM1-4	Condenser fan
VAR	Varistor	EM	Evaporator fan
KT1-2	Time Relay	SH1-2	Sump heater
PRF	Phase protection	BR1-2	Bypass Relay
KA1-2	Intermediate relay	TK5	Compressor protect
KA3-4	Fault Relay		



MODEL OF COMPRESSOR
SZ161-4/SY240-4

Mark no.	Locations	file no.	Sign.	Date
Designed		Standard		
Checked		Ratified		
Approved				
Technology				

Phase	Wt. Scale	PHE100-Bb2-R
3 Ph	1:1	
Total	No.	Wiring Diagram

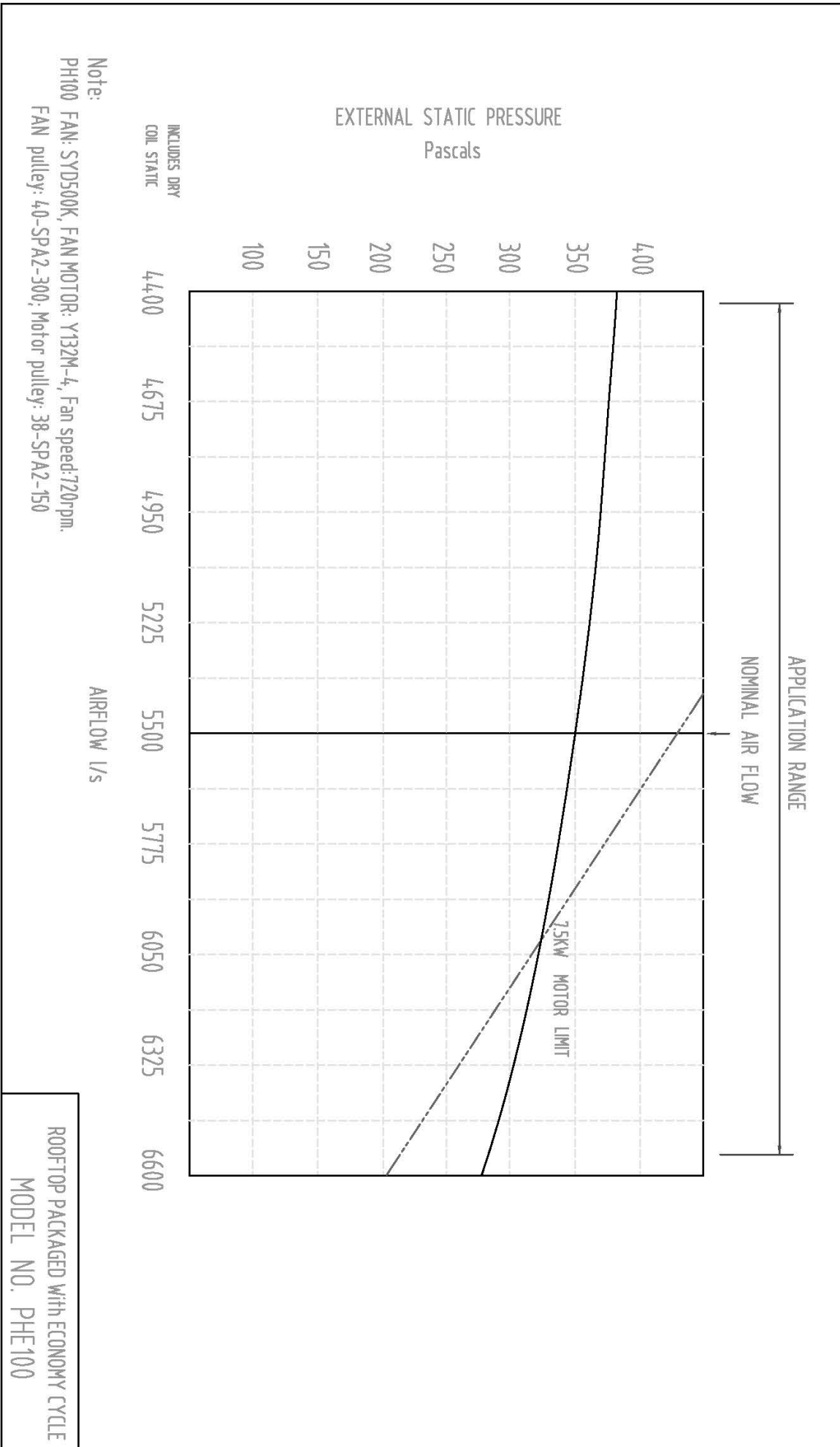



PHE100 Sound Pressure Curve

A Class: 77.0dB

Hz	dB
64Hz	50
125Hz	61
250Hz	64
500Hz	73
1000Hz	71
2000Hz	71
4000Hz	69
8000Hz	62

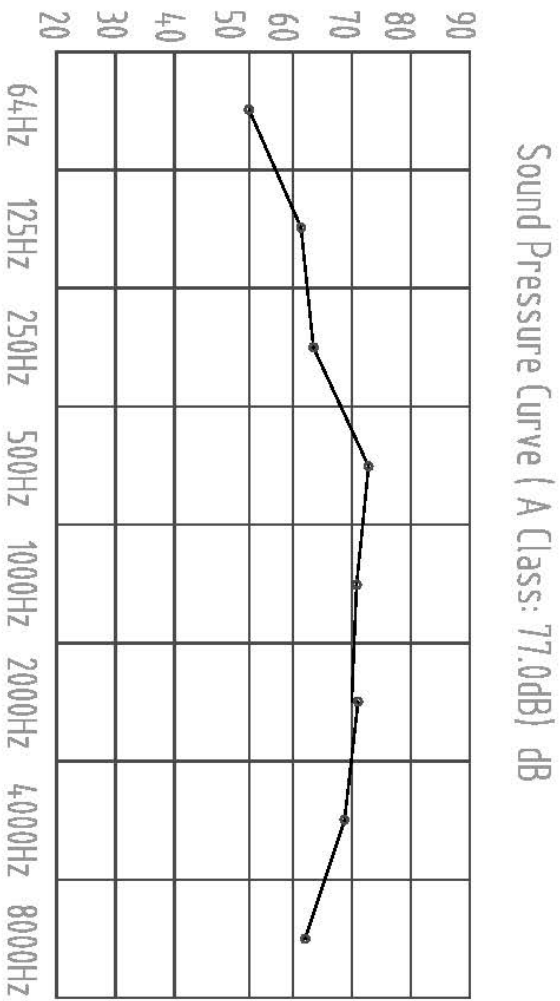
Note: Occupant at least 1.0m from sound source.



DRAWN BY: Chen Cheng	DATE: 13th, Feb, 2014	
APPROVED Q.A.: Zhu Junquan	APPROVED ENG.: Li Meifen	
TITLE: Packaged Rooftop With Economy Cycle PHE TYPE		
MODEL: PHE100	DRAWING NO.: 01	ISSUE: 01
		SHEET SIZE: A4