

Fan Coil Unit

Floor Exposed

FCU20

Model Number Configuration

FCU20-ML-2 : 2 Row Floor Exposed
 FCU20-ML-3 : 3 Row Floor Exposed

PERFORMANCE DATA

RETURN AIR

Model	Row	Air Flow			Rated Cooling Capacity	Rated heating Capacity	Water Flow	Water Resistance	Noise	Input Power	Weight
		L/S									
		H	M	L							
FCU20-2	2	94	74	58	1.77	2.66	0.08	4	35	31	20
FCU20-3	3	94	74	58	2.10	3.35	0.1	5	35	31	21

Notes for Return Air:

1. Cooling: Air on temp. DB/WB 27°C/19.5°C, Water in/out temp. 7°C/12°C.
2. Heating: Air on temp. 21°C DB . Water in temp. 60°C.

SPECIFICATION

- Forward curved centrifugal fan
- Single phase motor & direct drive
- Coils: Copper tube & Aluminum fins
- Galvanised sheet casing
- A3 steel sheet painting drip-tray
- Capacitance type motor

Floor Exposed

FCU20

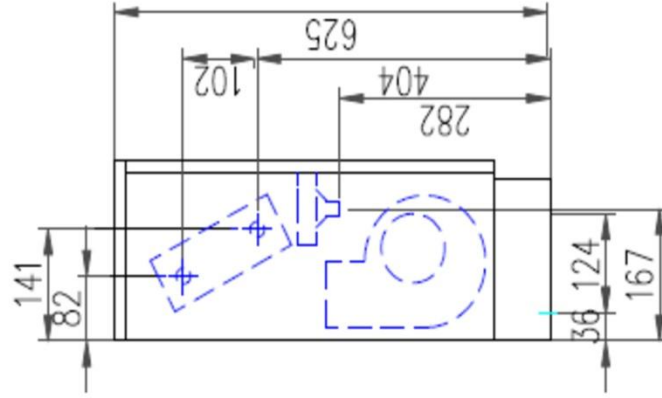

- 1. Water Inlet 3/4 FPT
- 2. Water Outlet 3/4 FPT
- 3. Condensation 3/4 MPT

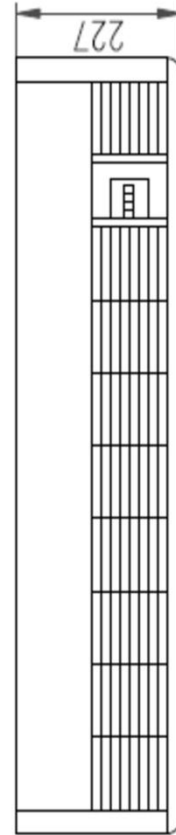
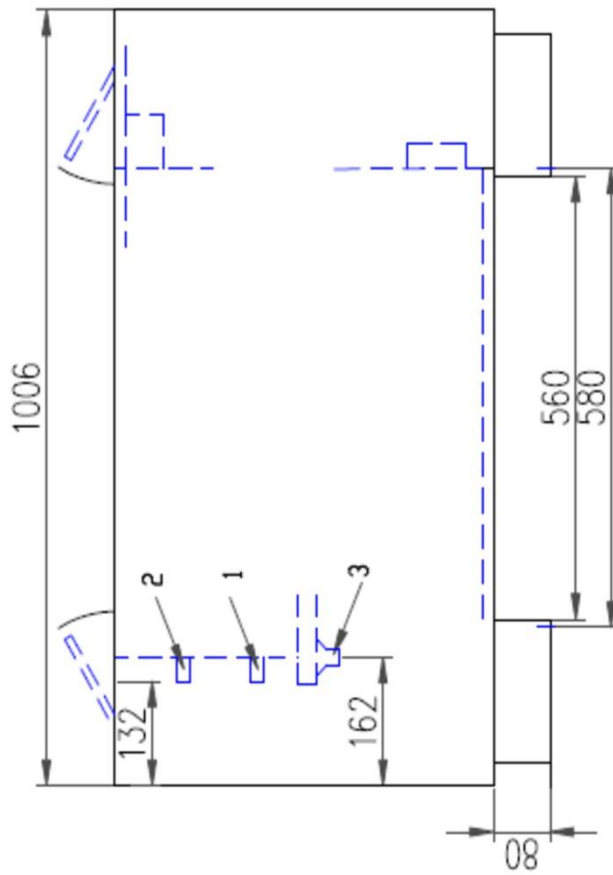

DRAWN BY:	DATE:	
APPROVED Q.A.:	28/09/16/12	
APPROVED E.M.:	APPROVED ENG.:	TITLE: Water Cooled Fan Coil Unit
MODEL:	FCU20ML	FCU TYPE
		DRAWING NO.1
		SCALE:
		ISSUE:
		SHEET 1 OF 1
		SHEET SIZE:
		A4

FAN COIL UNIT

Floor Exposed FCU20

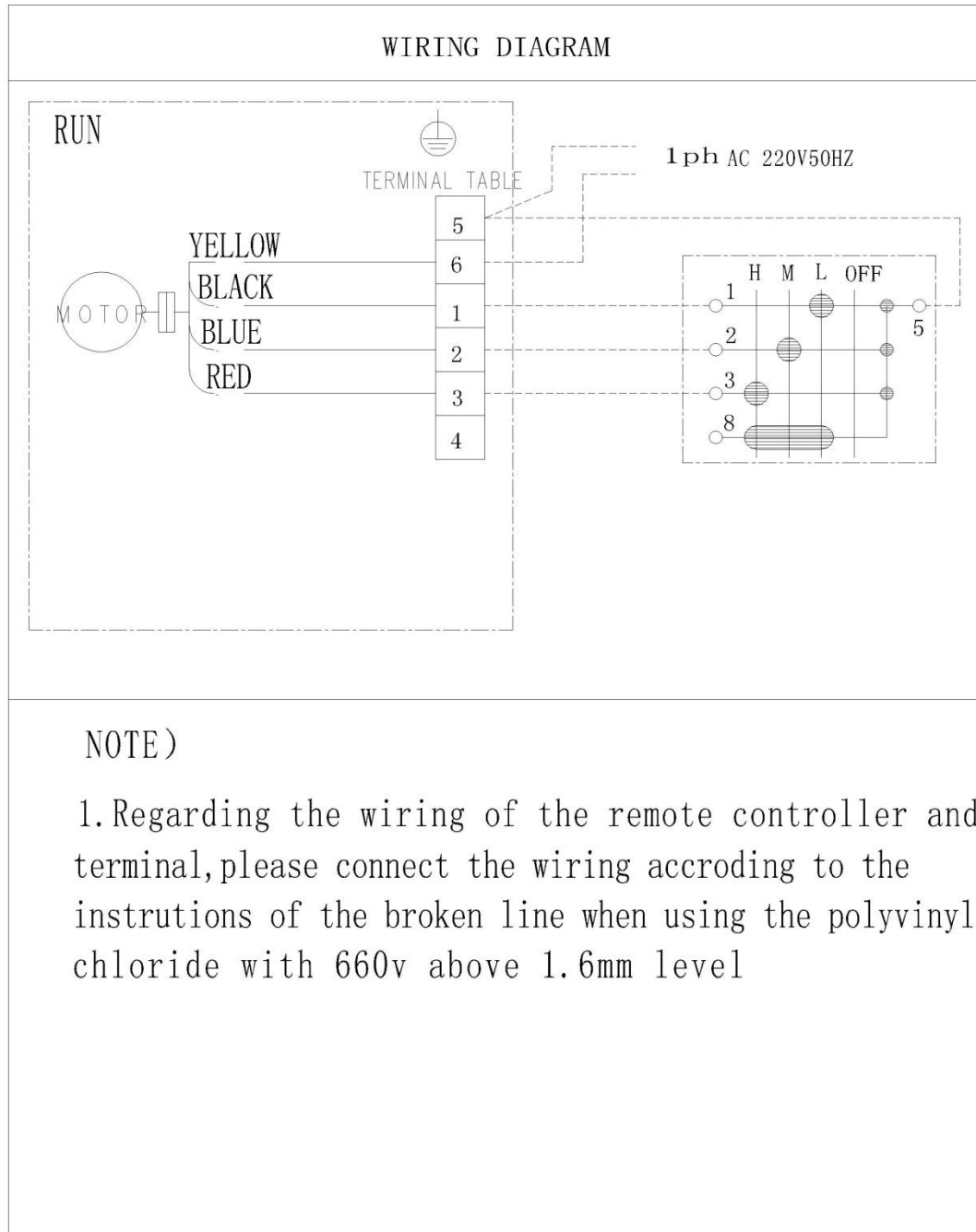

FAN COIL UNIT

*Floor Exposed
FCU20*

FAN CURVE

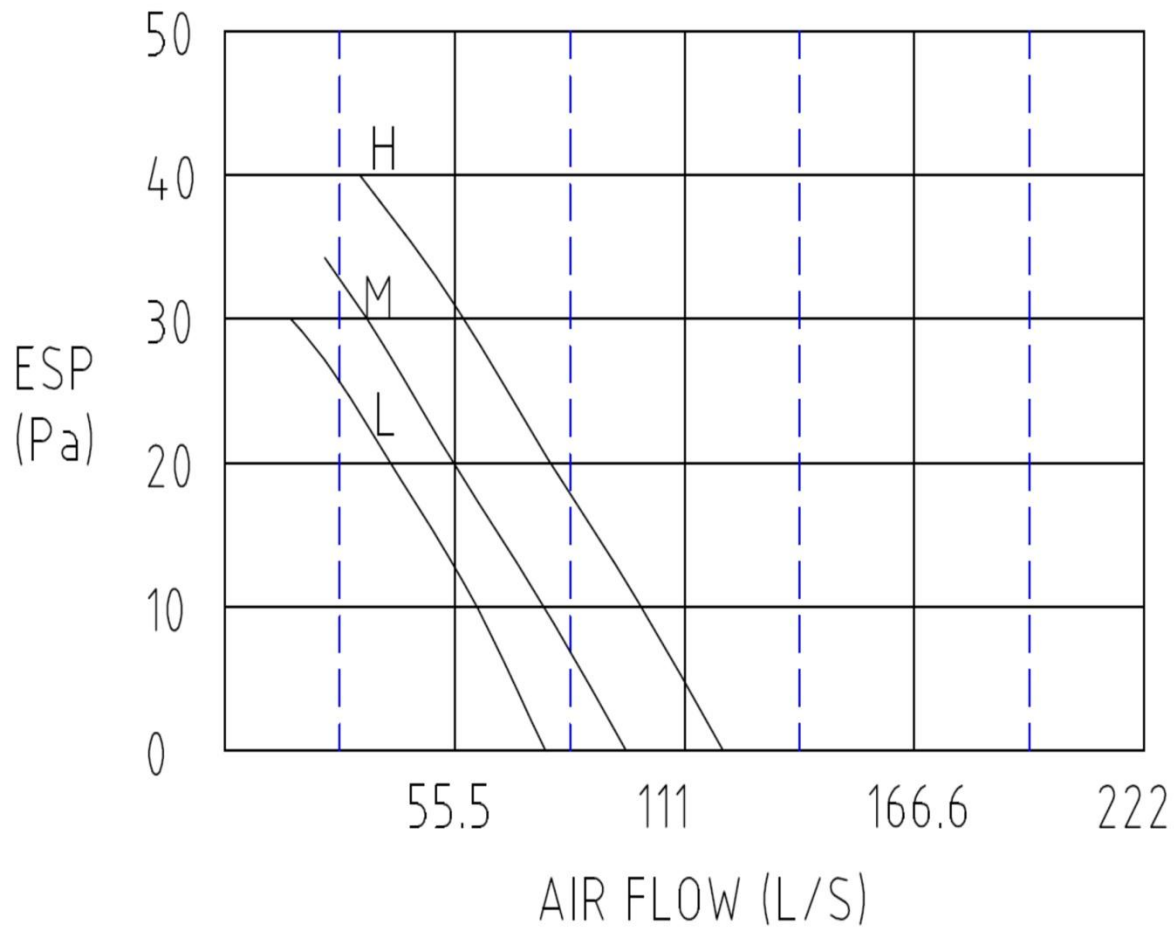

FAN COIL UNIT

Floor Exposed FCU20

NOISE CURVE

