



ECONOMY *CYCLE*

Rooftop Packaged and Split Ducted Air Conditioners



www.dunnair.com.au



Dunnair

Quality Engineering Solutions

Dunnair is now firmly positioned as a leading supplier to the air conditioning industry.

The name Dunnair is synonymous with high quality products in the commercial air-conditioning industry. Beginning with Dunn Air Conditioning in 1961 and more recently, Dunnair International and Dunnair Australia, the company continues to be a leading supplier of air-conditioning units for the Australian market.

In 1994, the company was bought by Multistack and renamed Dunnair International. In 2004, Ernest Ugazio acquired the sales and subsequently state service department of Dunnair. This led to the company being divided into separate entities: Dunnair International and Dunnair Australia, the former focused on Multistack Chiller sales and spare parts; while the latter began design and development of a split ducted and rooftop packaged range that was manufactured in China. More recently, in April 2018, Air Change Group acquired Dunnair Australia, solidifying Dunnair's position as a manufacturer of high quality, specified air conditioning units.

Dunnair will design, build and deliver HVAC equipment to meet the most stringent specifications and difficult applications.

“We make special equipment.”

The **Air Cooled series of split ducted units** shown in this brochure are part of Dunnair's range of high quality units for every application. Dunnair has also become the first choice when individual engineering solutions are required. Fast-moving and responsive, Dunnair supplies made-to-measure HVAC solutions to a growing number of high profile developments across Australia.

Dunnair research and development plus a strict quality control program have been fundamental to our growth, success and reputation. Dunnair units are manufactured in accordance with strict quality control standards and are MEPS rated and developed for Australian conditions.

Range: Dunnair's modern factories manufacture 16 separate product lines and some 600 different models. Dunnair can supply most products the HVAC industry requires. The recent acquisition by Air Change, a company known for its award winning innovation, is proof that the company is working continuously to improve its product range and the efficiency of its products.

Specialised Solutions: Dunnair will engineer and manufacture equipment to suit the application and building design. No challenge will go unaccepted. We will design and make special products as required for the building, mining, transport and maritime industry. We employ mechanical engineers in all sales offices in Australia. Their role is to supporting designers to achieve their goals.

Our promise to system designers is: **“Tell us what you need and we will work with you to deliver”.**

With a head office in Sydney, Dunnair also has offices in Victoria and Queensland. Dunnair maintains a dedicated engineering and sales support staff waiting to assist you with technical and product information and provide valuable solutions for your project.



Economy Cycle

Rooftop Packaged and Split Ducted Air Conditioners

Economy cycle systems are compulsory on larger commercial buildings depending on size and geographical location within Australia. Traditionally, economy cycle systems were designed as a part of rooftop ductwork; an expensive and time consuming practice.

For over 50 years Dunnair has been a leading innovator of new products and systems in the HVAC industry. The concept of the economy cycle system is not new, but it took Dunnair's ingenuity to incorporate this function into one unit. This new range of rooftop packaged air conditioners has been operating in a considerable number of buildings across Australia since 2009. These units have made life much easier for building designers, consultants, builders, air conditioning contractors, electricians and most importantly, end users.



The obvious benefits are cost savings in both labour and materials. For example, the pairing of the Dunnair Economy Cycle range with the viking module thermostat makes electrical wiring less complicated thereby reducing control installation costs.

The Dunnair Economy Cycle Rooftop Packaged range enables a better air conditioning system on all fronts with more fresh air, reduced running costs, less service and maintenance and a much more user friendly control interface.

The importance and benefits of installing a self contained Dunnair economy cycle rooftop packaged air conditioner is self-evident when considering what this can deliver:

- More fresh air to the conditioned space providing a healthier environment.
- In ideal conditions a saving of up to 70% on running costs.
- Increased rates due to the carbon tax will be partially offset by using the economy cycle function.
- The ability to vary the amount of fresh air from 10% to 100% to achieve maximum benefit from the system.
- Initial investment will be offset by reduced energy bills over the long term. *

Dunnair economy cycle rooftop packaged air conditioners are also designed in split ducted type. There are 47 models in total available in both rooftop packaged and split ducted type. The capacity range starting from 6kW through to 200kW will satisfy almost any system requirement.

Dunnair recommends the economy cycle air conditioner for both domestic and commercial applications in all parts of south and south eastern Australia where in spring and autumn the internal temperature of a building can be maintained with a high proportion of fresh air.

*Statement is made based on typical application of Dunnair Economy Cycle air conditioner.

Features

- PHSE8 – PHSE35 single stage
- PHE40 – PHE200 two stage
- PHSE8 – PHSE35 direct drive
- PHE40 – PHE200 belt drive
- Automatic De-Ice
- Liquid accumulator
- Crankcase heater
- 24 volt control
- Galvanised steel panelling
- Thermal break frame and panels in future
- Durable powder coated cabinet (outdoor unit)
- External stainless steel fittings
- Easy access panels with turn lock handles, no screws
- 25 mm insulation
- Coil corrosion protection
- Dry filter
- High quality scroll compressors
- High/low pressure protection for compressor
- Time delay protection for compressor
- Limit start timer
- Quiet and efficient
- Individual defrost dual circuit units for two stage units
- Reverse phase protection
- Electric reheat high temperature protection (optional)
- Overload protection for both indoor and outdoor fan motor
- MEPS IV approved
- Manufactured for Australian Standards & Conditions
- High quality control procedures
- R410a refrigerant is used in our standard units. Units with R407c refrigerant are available on request.

Optional Features

As an active market player in the commercial air conditioning industry, we understand that every project is unique. Standard manufactured units may not meet the requirements of your system design.

Dunnair always welcome enquiries for custom made air conditioning equipment.

Available options are listed below:

- Two stage for 18 – 35 kW units
- 50 mm insulation
- Fan upgrade (High external static pressure)
- Stainless steel condensate tray
- Belt drive instead of direct drive fan
- All copper coils (see image)
- Stainless steel casing (see image)
- Change location of supply return air
- Anti-corrosion marine grade coil coating black fin
- Hot gas bypass
- EC motor
- EC plug fan
- EC condenser fan
- Two speed condenser fan
- High static centrifugal condenser fan for plant room
- Other Customised options available. Please contact your local Dunnair sales office

Applications

These units have been specifically developed for air conditioning in commercial premises; for example, shopping malls, offices, banks, factories and restaurants.

System Working Principle

Normal Operation

Fresh air motorised damper 1 Closed
 Return air motorised damper 2 Open
 Relief air motorised damper 3 Closed

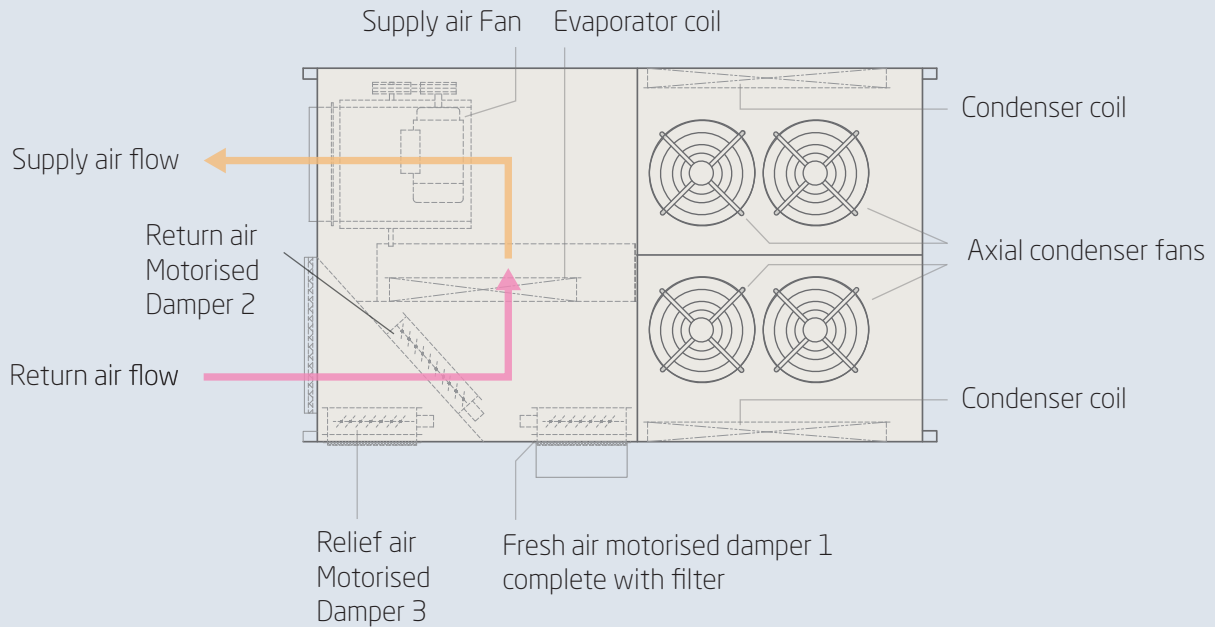

Example Ductwork

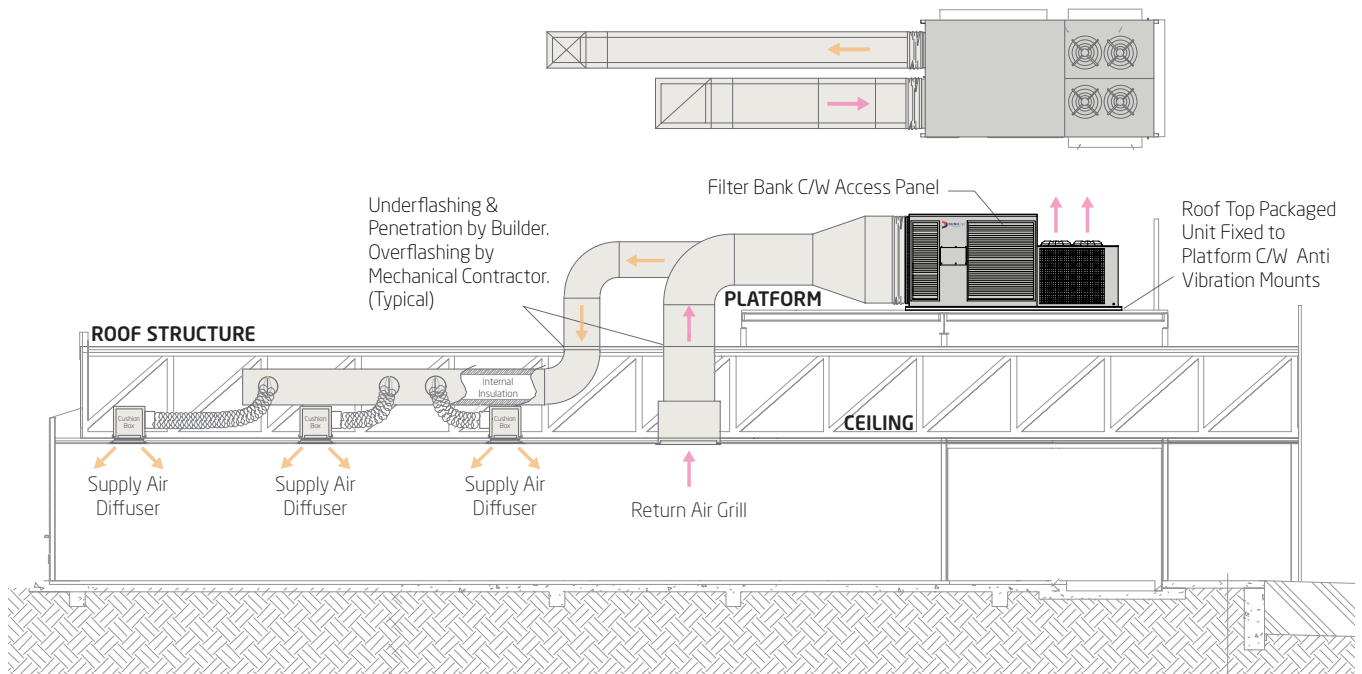

Economy Cycle Mode 1

- Fresh air motorised damper 1 Open
- Return air motorised damper 2 Closed
- Relief air motorised damper 3 Open

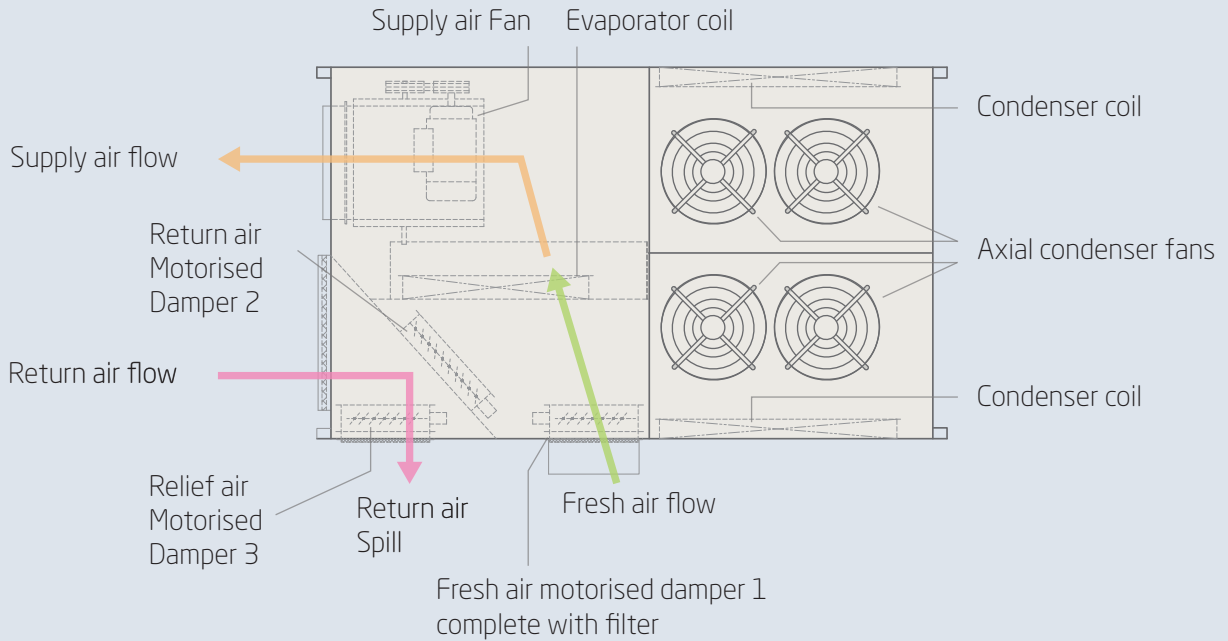

Economy Cycle Mode 2

- Fresh air motorised damper 1 Open
- Return air motorised damper 2 Open
- Relief air motorised damper 3 Open

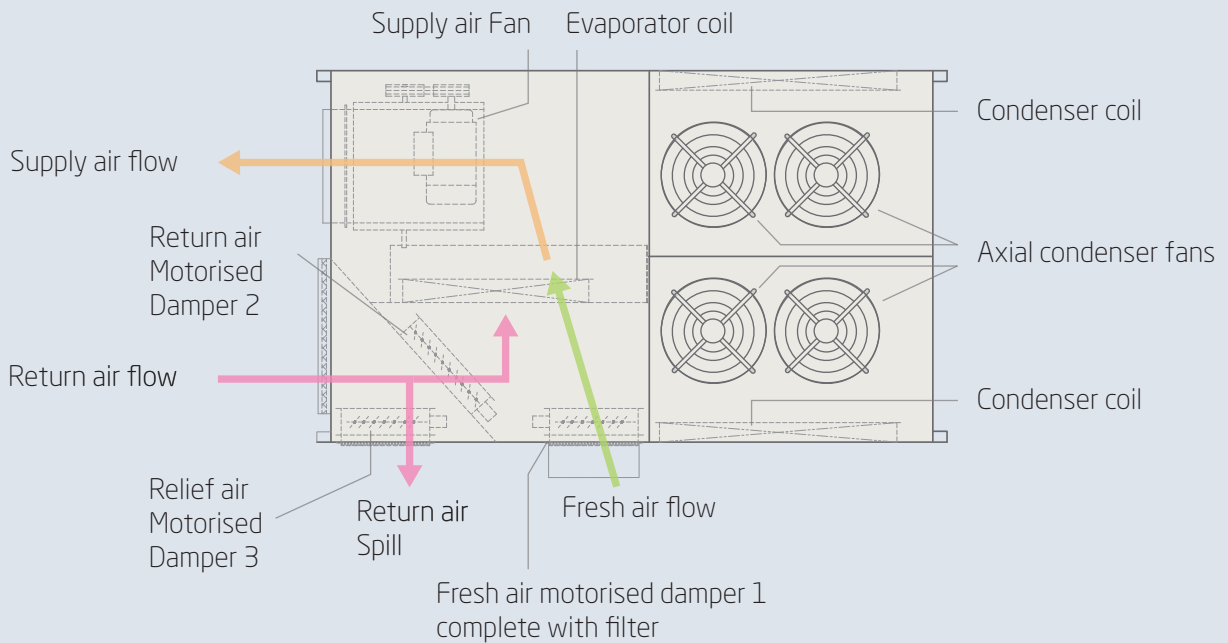

Refrigeration System

All units are factory charged with R410A refrigerant.

Compressor

Our high efficiency scroll type compressor is hermetically sealed, quiet running and supported on rubber mounts to minimise vibration

Nomenclature

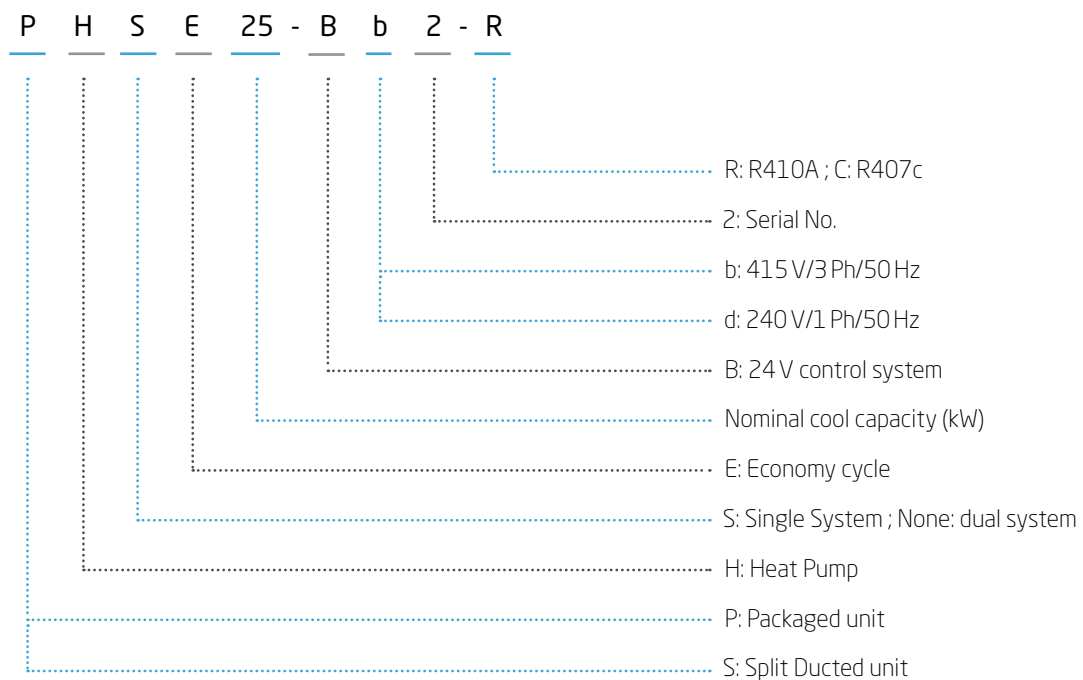

Safety Features

1. High and low pressure protection
2. Indoor and outdoor fan overload protection
3. Compressor delay timer
4. Circuit breakers
5. Time and temperature controlled electronic de-ice switch prevents icing up of the outdoor coil during heating cycle
6. Integrated fault run terminal
7. Crankcase heaters

Optional Controller Features

- Up to four stage compressor control
- Integrated communications (Modbus & BACnet).
- Integrated Economy function
- 365 day, seven day, or manual operation
- Security PIN protected menus.
- Smart two-wire sensors with multiple functions
- Averaging
- After Hours run function
- Force system Off
- Force ventilation (fan only) mode
- Optional RF & communicating sensors available
- Two programmable auxiliary inputs
- 0 – 10V heating & cooling valve control
- Occupancy inputs with individual set point control.
- 24 V or 240V, AC powered.
- Volt free relay outputs – 240V, 10 A max.



Specifications

Input Voltage	24/240 V (+/- 15%); 50/60 Hz
Operating Temperature	0 – 50°C (32 to 122°F)
Operating RH	0 – 95% (non-condensing)
Storage Temperature	0 – 65°C (32 to 150°F)
Size	110 x 110 x 65 mm 110 x 110 x 65 mm with terminal covers fitted
Control range	0 – 50°C
Maximum Equipment Stages	4 compressors (HC made = 2 heat 3 cool)
Anti-cycle timer	Off, 2, 3, 4 or 5 minutes (installer adjustable)
After hours timer	Off to 12 hours (installer adjustable)
Memory type	Non-volatile 128 kB
Clock	12/24 hour 7 days with calendar Backup battery for clock (CR1220)
Backup battery life	5 to 8 years
Holiday events	10 - (Perpetual and/or self expiring)
LCD	32 x 132 graphical – led back light
Relays	Fan: 10 A, 240V max – volt free All others: 5 A, 240 V max – volt free
0-10V output	10 mA max each
Room & outside air sensor	10K NTC type II (2 wire screened)
Communicating sensor	3 wire – 400 m maximum with control function 10K NTC type II/ RH 10 – 98% RH 2%
Optional RF sensor	2 x AAA batteries, 10 month life, 10K NTC type II Range: 150 m open air (40 m indoors typical) Frequency: 433 MHz, 2 way with error checking
Communications	Modbus RTU Baud rate 4.8 / 9.6 / 19.2 K BACnet MS-TP Baud rate 4.8 / 9.6 / 19.2 K Address range 1 – 255

Specifications

Models PHSE8 - PHE200

Model	Total Cooling Capacity (kW)	Sensible Cooling Capacity (kW)	Heating Capacity (kW)	Nominal Air Flow (L/s)	Phase	Nominal Max Current (A)	Noise Level (dBA)	Refrigerant Circuits	Fan Drive
PHSE8	8.0	7.2	7.9	472	1	15.9	66.8	1	Direct
PHSE10	9.3	8.0	9.4	555	1	26.0	67.2	1	Direct
PHSE12	11.5	9.7	11.7	695	3	11.0	69.7	1	Direct
PHSE15	14.8	13.0	14.6	850	3	12.6	70.6	1	Direct
PHSE18	17.1	14.4	17.5	1000	3	14.6	70.4	1	Direct
PHSE20	20.5	16.3	20.7	1110	3	17.4	73.5	1	Direct
PHSE25	23.8	19.1	24.2	1390	3	22.4	74.9	1	Direct
PHSE30	30.6	24.9	30.6	1800	3	27.0	74.7	1	Direct
PHSE35	34.8	28.3	34.2	2000	3	28.7	75.2	1	Direct
PHE40	39.1	31.5	38.4	2200	3	30.8	68.2	2	Belt
PHE45	44.6	36.4	44.2	2700	3	37.2	70.3	2	Belt
PHE50	48.6	39.4	47.8	2800	3	41.2	71.3	2	Belt
PHE56	55.1	44.5	55.6	3000	3	47.7	72.3	2	Belt
PHE66	65.5	50.9	60.7	3500	3	54.5	71.2	2	Belt
PHE73	72.8	59.3	66.6	3900	3	60.6	73.0	2	Belt
PHE80	80.4	65.5	80.7	4300	3	66.2	75.8	2	Belt
PHE85	86.6	68.2	87.1	4500	3	63.2	75.8	2	Belt
PHE90	88.5	71.0	85.0	4800	3	74.4	73.6	2	Belt
PHE95	95.8	72.3	96.2	5200	3	74.4	76.0	2	Belt
PHE100	102.2	82.9	98.5	5500	3	85.2	77.0	2	Belt
PHE120	117.6	95.2	116.2	6500	3	98.8	76.0	2	Belt
PHE140	137.8	110.6	132.0	7500	3	117.5	80.2	2	Belt
PHE160	156.2	127.5	152.5	8500	3	133.9	77.6	2	Belt
PHE180	176.8	143.6	169.4	9500	3	153.2	80.8	2	Belt
PHE200	201.8	164.3	196.2	10500	3	163.7	83.2	2	Belt

Cooling Capacity is based on 27°C DB, 19°C WB Entering Air Temperature & 35°C Ambient Temperature

Heating Capacity is based on 21°C DB, Entering Air Temperature

Sound Levels are from 1 metre of the outdoor unit

Dimensions

Models PHSE8-PHE200

Model	Overall size (mm)				Spigot size (mm)		Damper size (mm)			
	Width	Depth	Height	Weight (kg)	Return Air (WxH)	Supply Air (WxH)	Fresh Air Damper (WxH)	Return Air Damper (WxH)	Relief Air Damper (WxH)	Number of axial condenser fans
PHSE8	1050	1704	800	268	320x650	270x180	250x500	250x500	250x500	1
PHSE10	1050	1704	800	268	320x650	270x180	250x500	250x500	250x500	1
PHSE12	1050	1704	865	300	320x650	300x221	250x500	250x500	250x500	1
PHSE15	1290	2000	865	332	400x700	282x237	320x600	320x600	320x600	1
PHSE18	1290	2000	865	340	400x700	363x275	320x600	320x600	320x600	1
PHSE20	1400	2000	850	448	760x400	325x338	320x600	320x600	320x600	1
PHSE25	1600	2250	1020	520	600x700	325x331	400x600	400x600	400x600	1
PHSE30	1800	2350	1010	618	700x800	455x331	400x800	400x800	400x800	2
PHSE35	1800	2350	1010	625	700x800	455x331	400x800	400x800	400x800	2
PHE40	1850	2450	1345	670	750x1200	507x507	400x1000	500x800	400x1000	2
PHE45	1850	2660	1345	680	750x1200	507x507	400x1000	500x800	400x1000	2
PHE50	1900	3010	1450	810	750x1300	507x507	400x1250	400x1250	500x1000	4
PHE56	1900	3010	1450	825	750x1300	507x507	400x1250	400x1250	500x1000	4
PHE66	2100	3320	1550	915	875x1400	569x569	500x1250	600x1100	500x1250	4
PHE73	2130	3320	1550	940	875x1400	569x596	500x1300	600x1100	500x1300	4
PHE80	2130	3320	1550	990	875x1400	571x496	500x1300	600x1100	500x1300	4
PHE85	2130	3420	1550	990	875x1400	569x569	500x1300	600x1100	500x1300	4
PHE90	2130	3400	1850	1060	800x1695	638x638	500x1500	600x1250	500x1500	4
PHE95	2130	3400	1850	1060	800x1695	638x638	500x1500	600x1250	500x1500	4
PHE100	2130	3710	1850	1250	800x1695	638x638	600x1500	600x1500	600x1500	4
PHE120	2130	4010	1950	1240	800x1695	638x638	700x1600	700x1600	700x1600	4
PHE140	2050	5700	1950	2140	1800x1750	715x715	800x1650	1000x1500	800x1650	4
PHE160	2050	5800	2000	2180	1800x1750	800x800	900x1650	1000x1500	900x1650	4
PHE180	2150	6200	2350	2480	1900x2100	900x900	900x1800	1050x1850	900x1800	4
PHE200	2150	6200	2350	2520	1900x2100	900x900	900x1800	1050x1850	900x1800	4

Diagrams

Models PHSE8-PHE120

RELIEF AND FRESH AIR ELEVATION

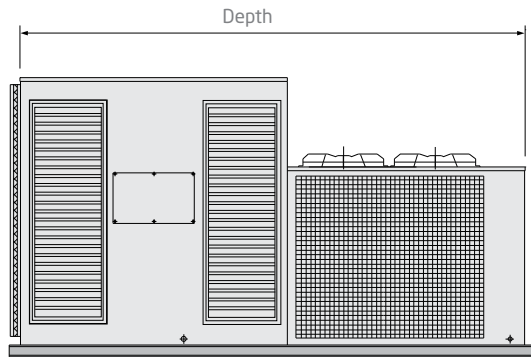

SUPPLY AND RETURN ELEVATION

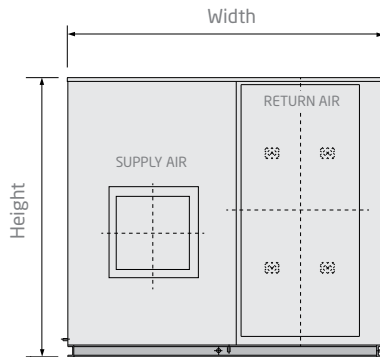

PLAN

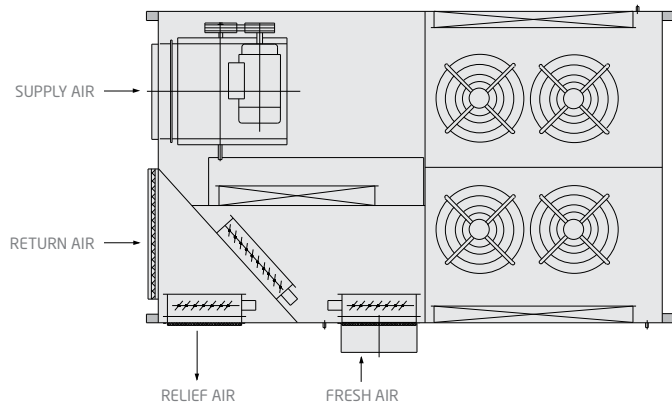

Models PHE140-PHE200

RELIEF ELEVATION

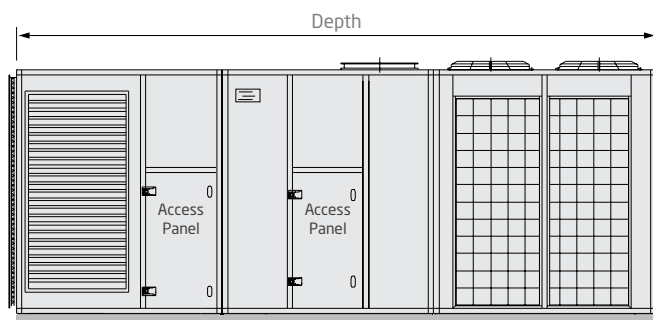

RETURN ELEVATION

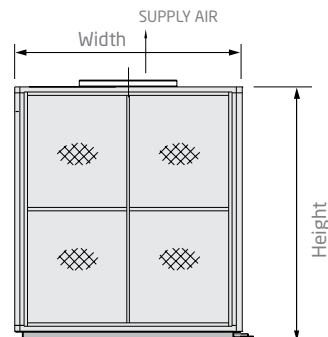

PLAN

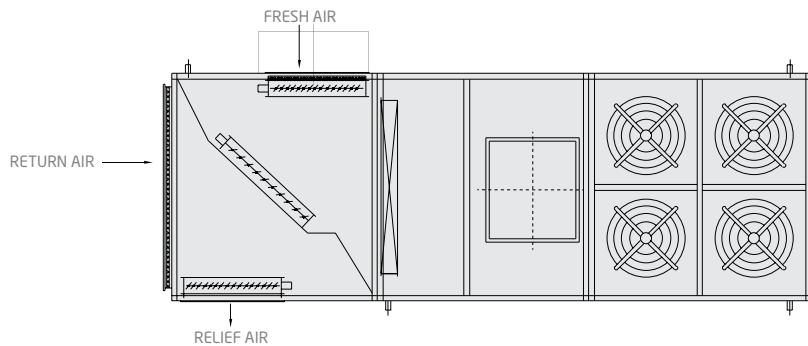

SHE Model Example*

Specifications and Dimensions for SHE Models available on request.

Model	Outdoor Unit			Indoor Unit			Supply Air Spigot		Return Air Spigot	
	Length	Width	Height	Length	Width	Height	Width	Height	Width	Height
	A	B	C	D	E	F	G	H	I	J
SHE56*	1520	1250	883	1600	1100	860	516	452	1400	727

* Example figures may not reflect actual dimensions

SUPPLY ELEVATION

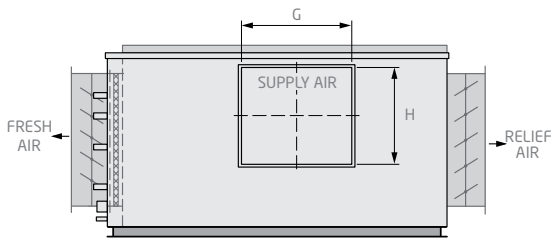

FRESH AIR ELEVATION

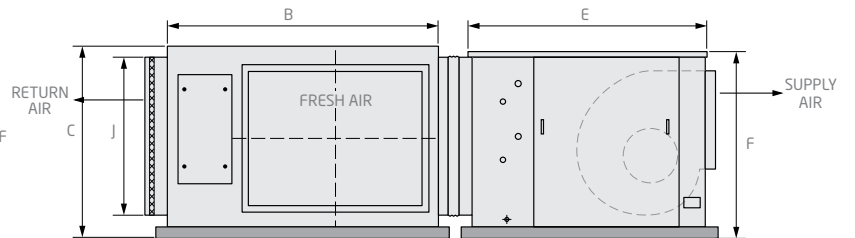

PLAN

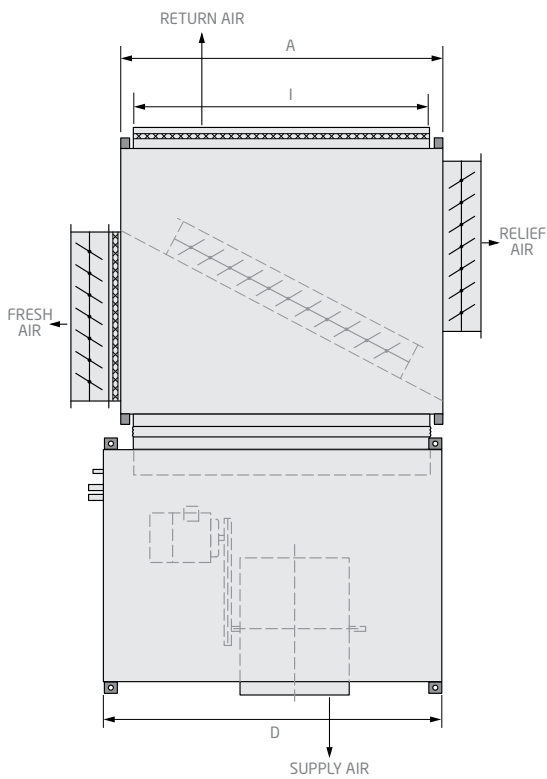

Fan Curves

Air Handling Performance

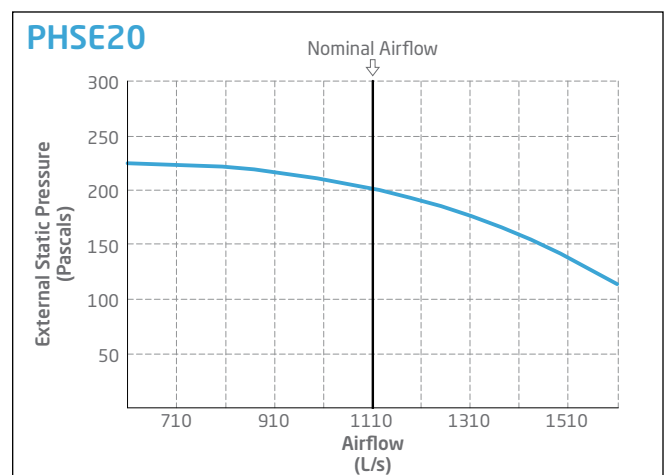
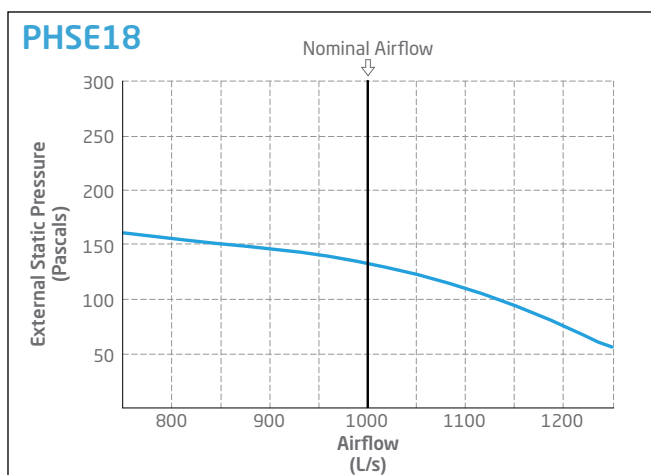
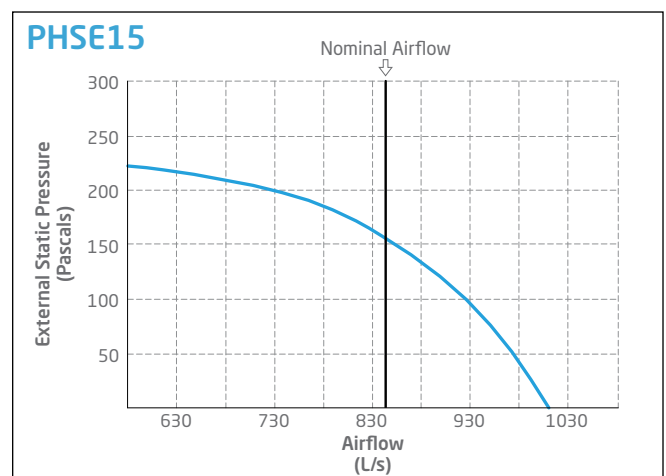
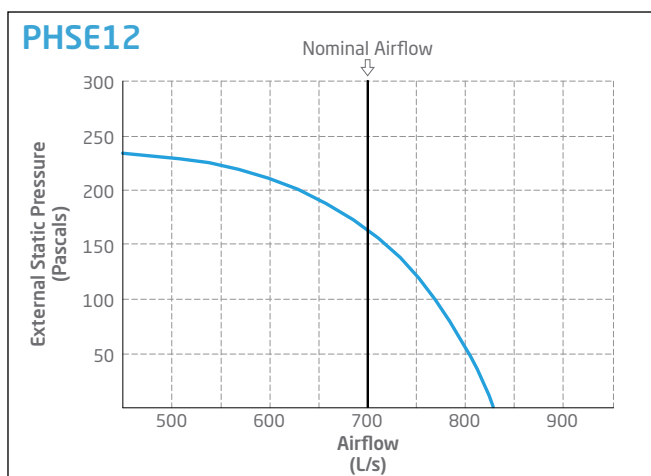
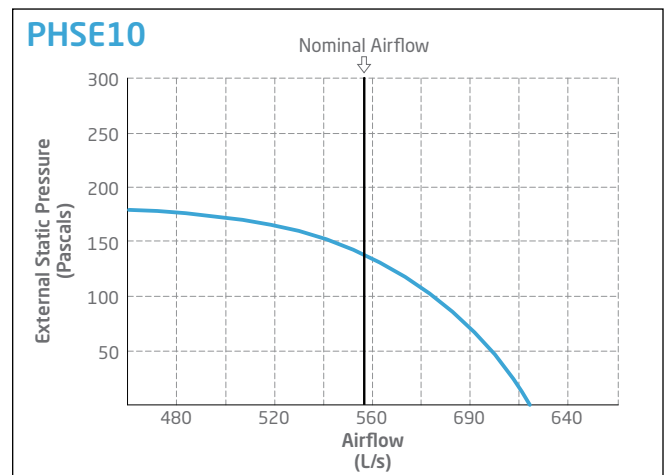
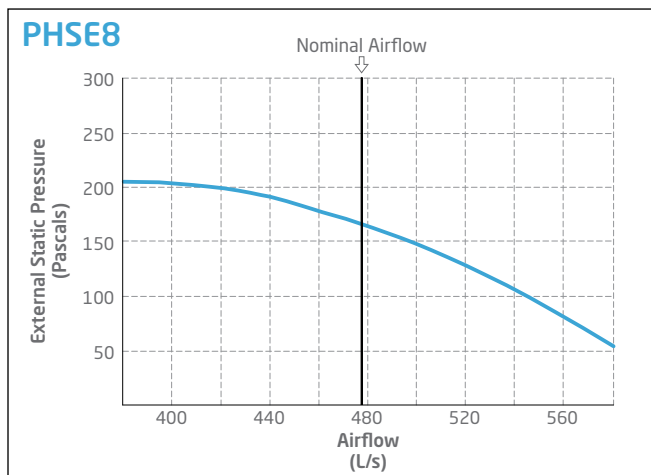

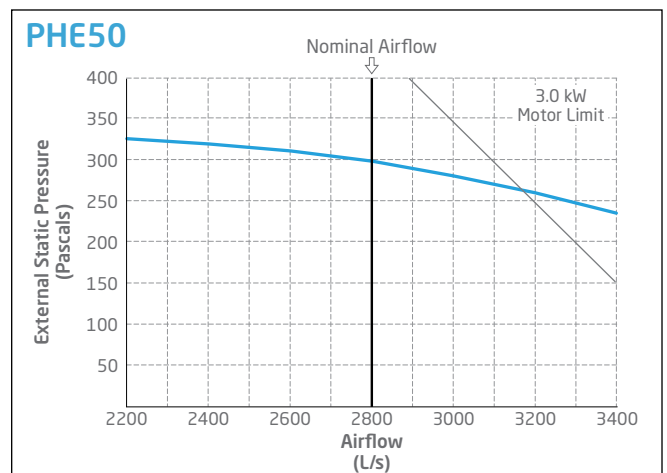
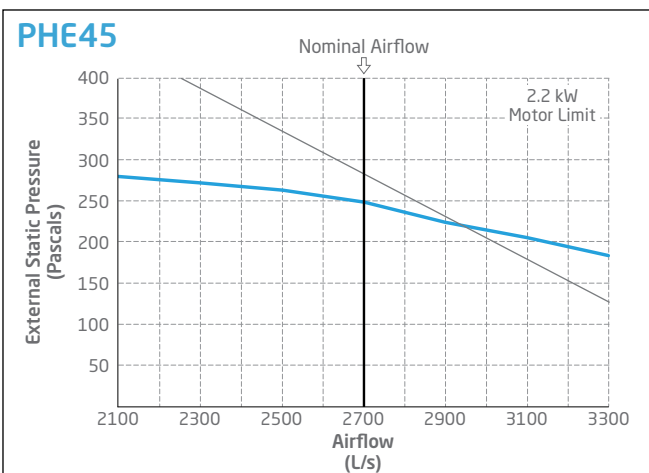
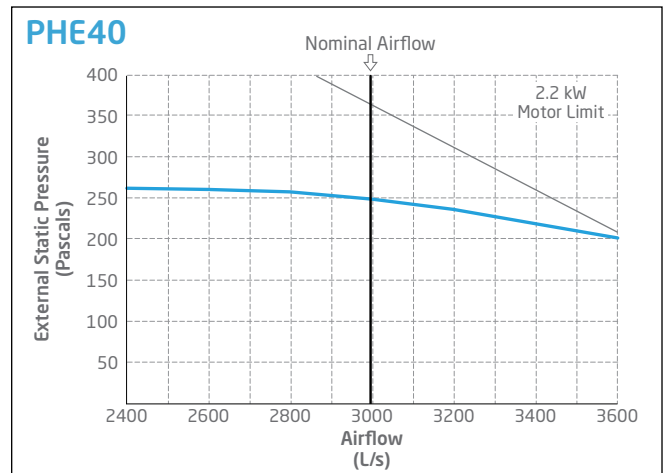
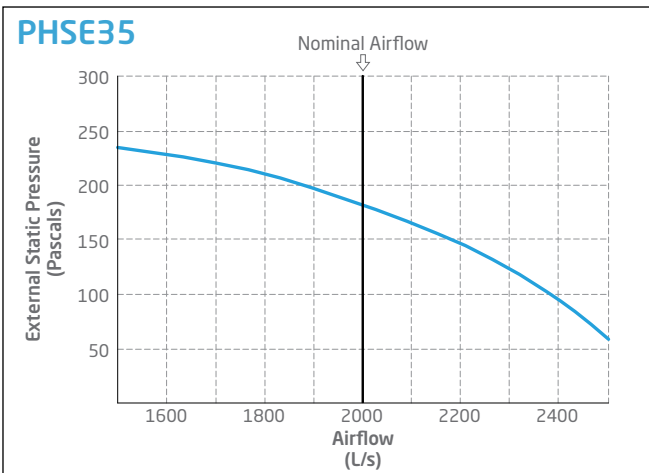
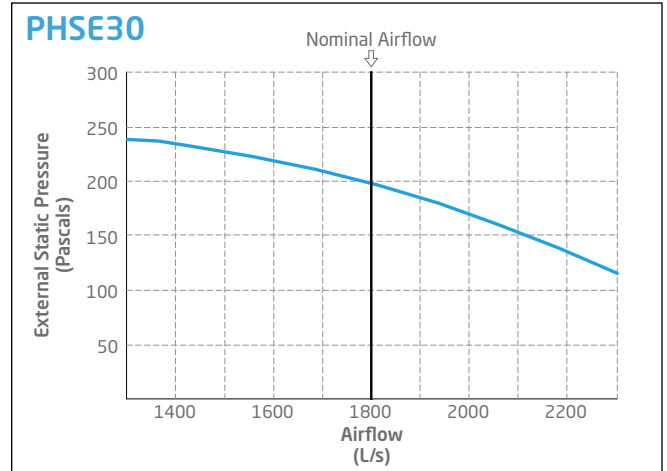
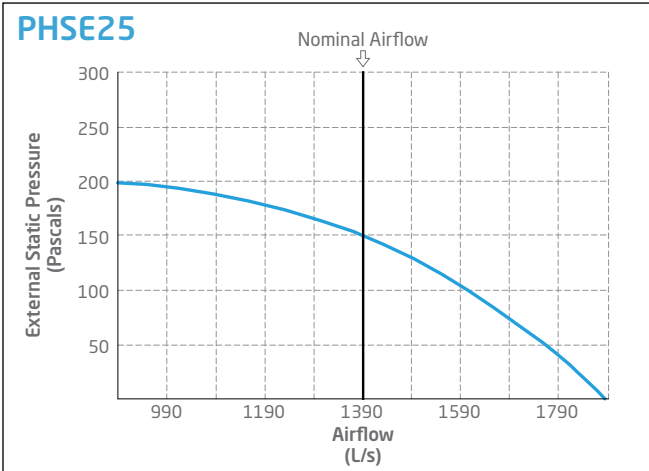

Fan Curves

Air Handling Performance

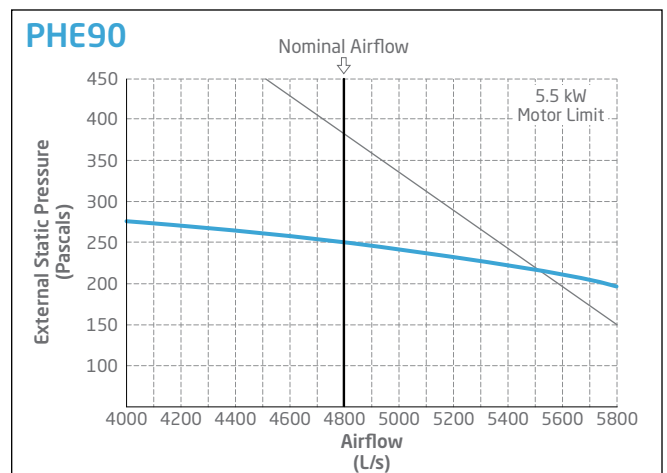
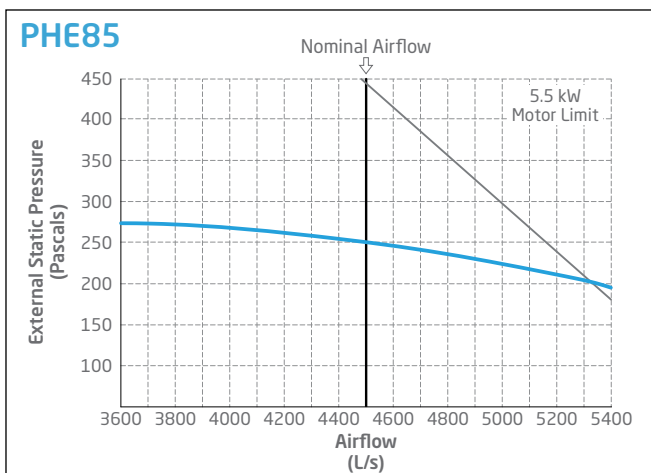
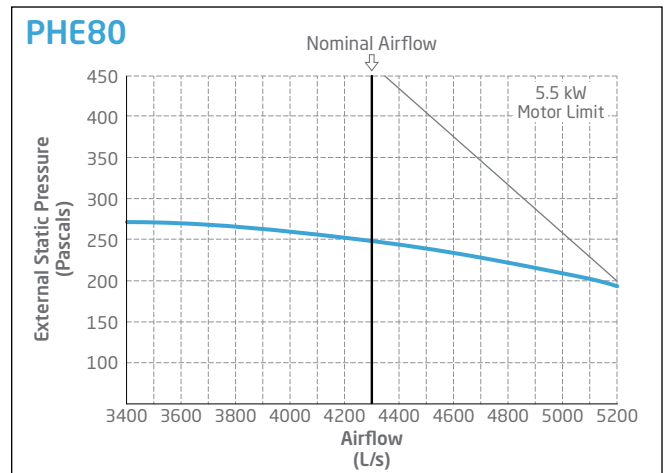
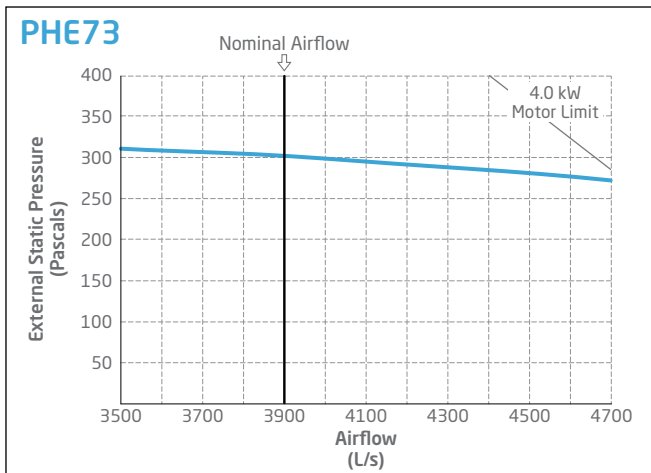
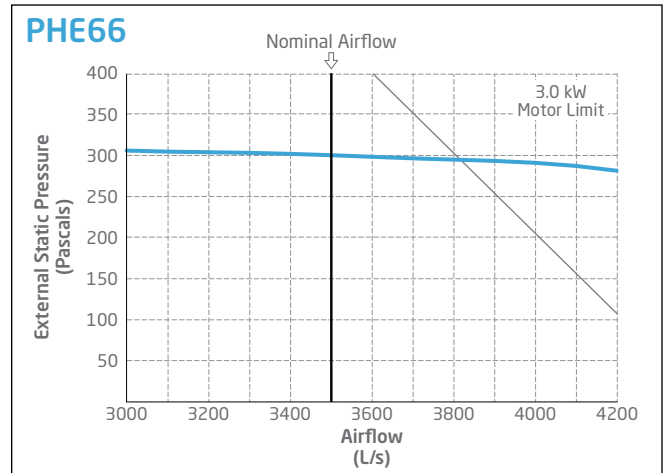
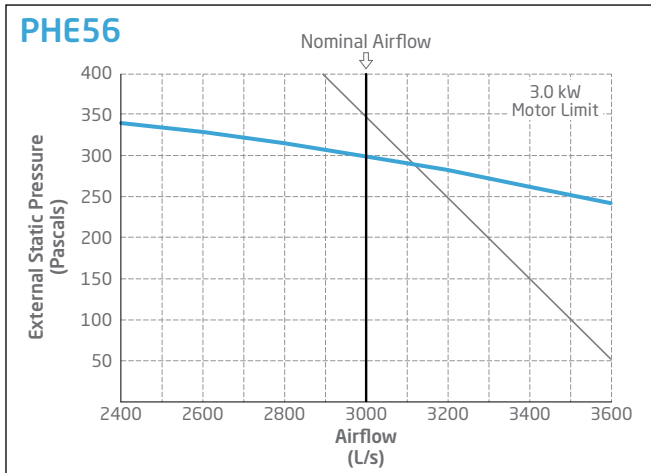

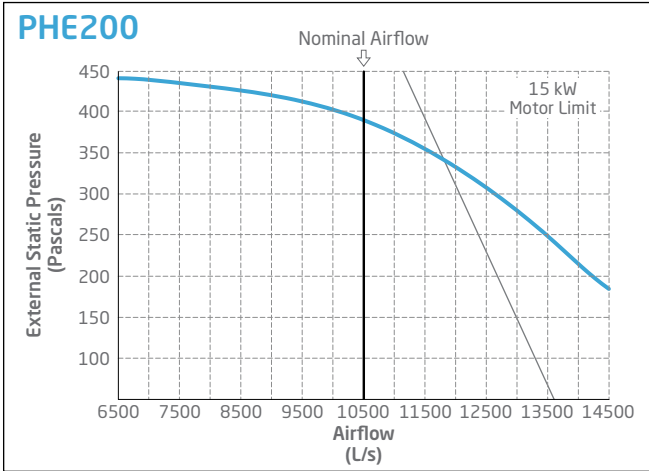
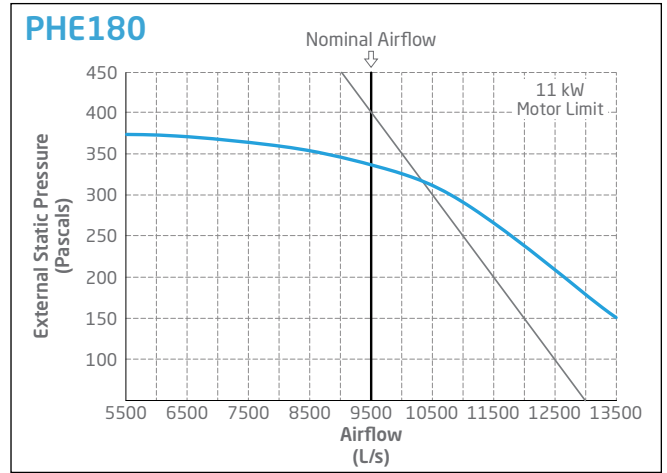
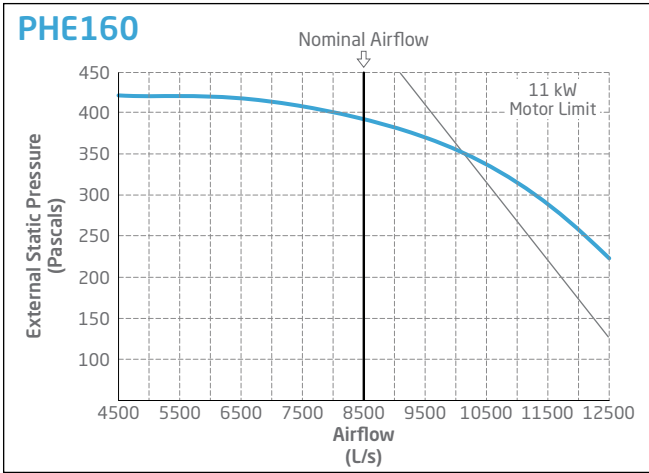
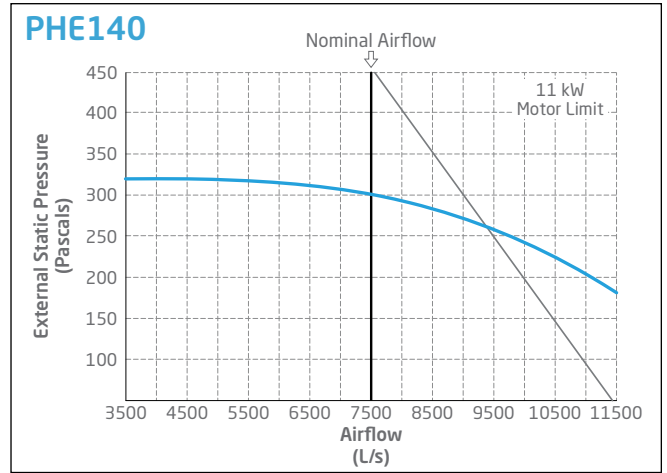
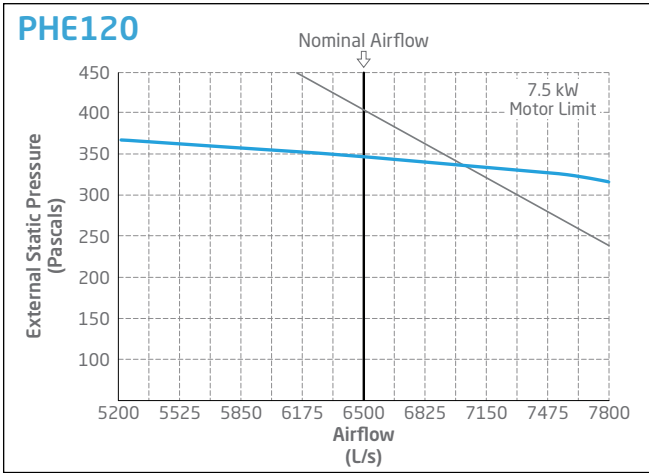
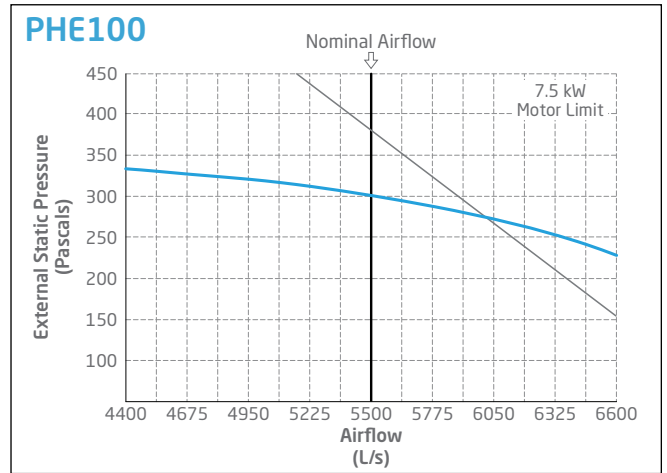
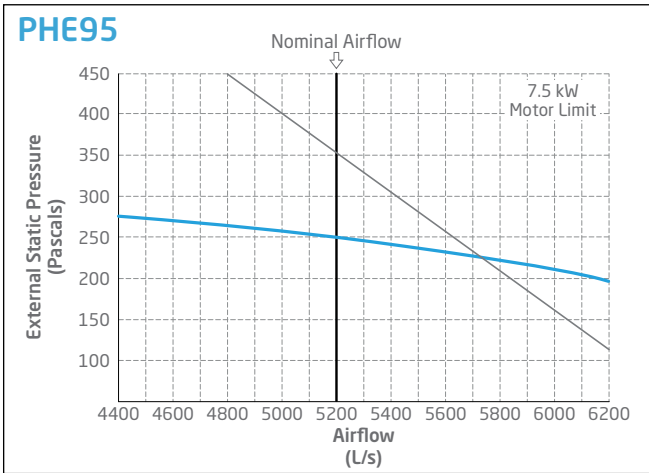

Sound Pressure Curves

PHSE8

A Class: 66.8dB*

Frequency (Hz)	Decibel (dB)
64	79.3
125	75.0
250	69.0
500	64.0
1000	62.2
2000	57.6
4000	51.0
8000	43.6

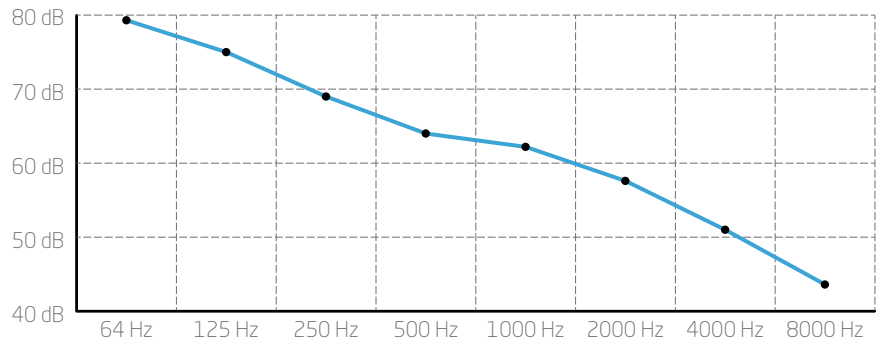

PHSE10

A Class: 67.2dB*

Frequency (Hz)	Decibel (dB)
64	76.5
125	72.3
250	69.6
500	66.1
1000	62.6
2000	53.1
4000	48.6
8000	41.8

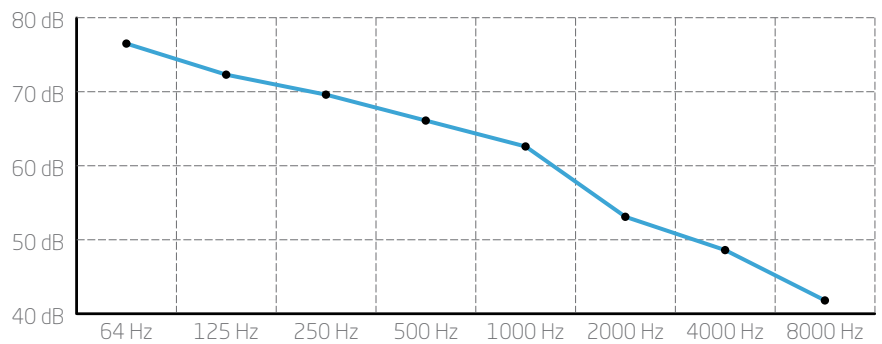

PHSE12

A Class: 69.7dB*

Frequency (Hz)	Decibel (dB)
64	76.8
125	71.5
250	69.8
500	70.5
1000	70.6
2000	64.8
4000	58.0
8000	49.3

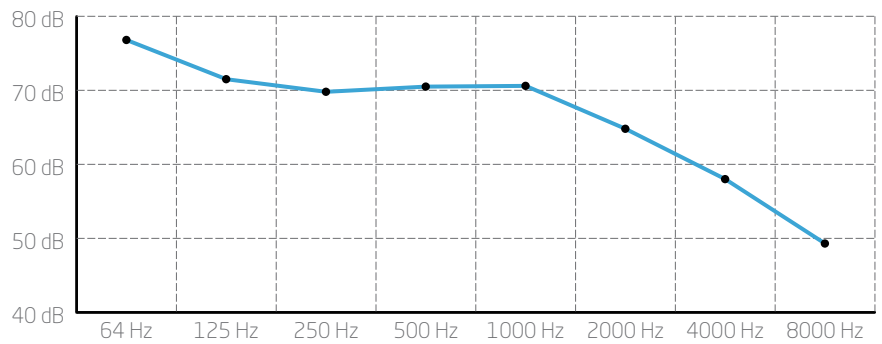

PHSE15

A Class: 70.6dB*

Frequency (Hz)	Decibel (dB)
64	76.5
125	72.9
250	68.9
500	67.0
1000	66.7
2000	60.9
4000	55.3
8000	48.0

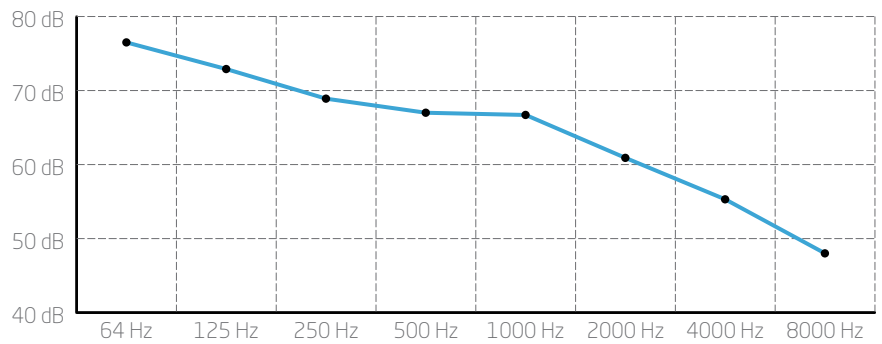

*Occupant at least 1.0 m from sound source.

PHSE18 **A Class: 70.4dB***

Frequency (Hz)	Decibel (dB)
64	77.3
125	72.1
250	69.0
500	66.2
1000	65.9
2000	61.1
4000	55.5
8000	47.2

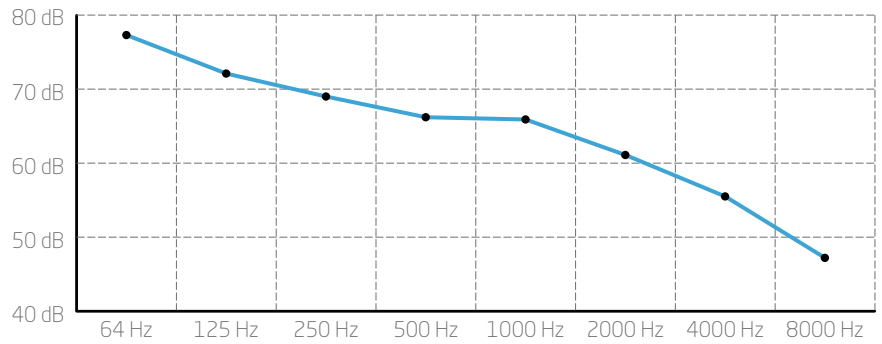

PHSE20 **A Class: 73.5dB***

Frequency (Hz)	Decibel (dB)
64	77.3
125	74.0
250	72.8
500	73.1
1000	72.5
2000	69.3
4000	59.2
8000	49.3

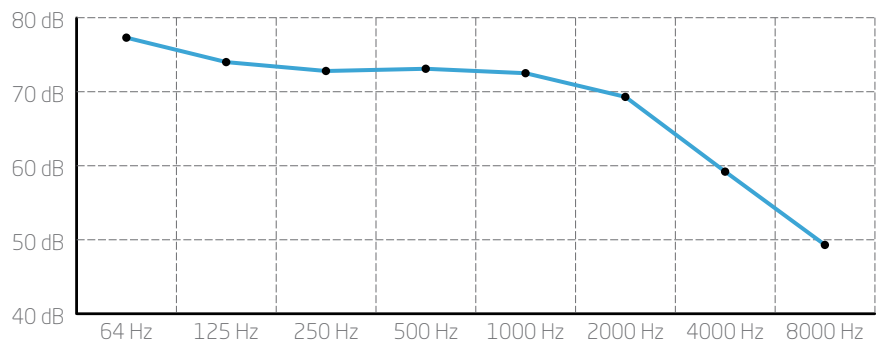

PHSE25 **A Class: 74.9dB***

Frequency (Hz)	Decibel (dB)
64	78.1
125	74.0
250	73.8
500	73.1
1000	71.5
2000	69.3
4000	58.7
8000	51.9

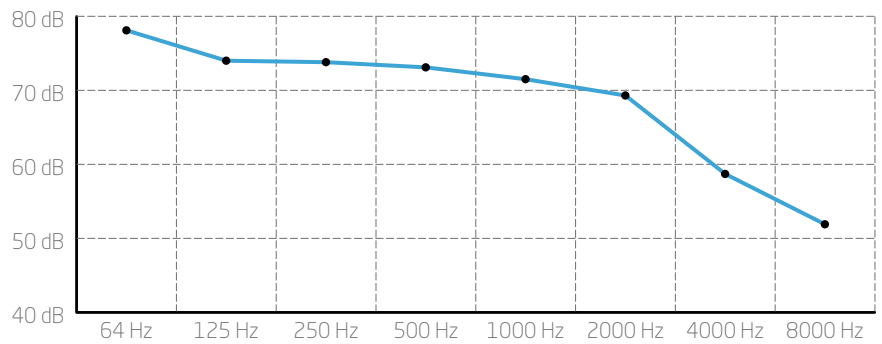

PHSE30 **A Class: 74.7dB***

Frequency (Hz)	Decibel (dB)
64	77.2
125	71.8
250	71.5
500	72.4
1000	71.0
2000	65.6
4000	59.7
8000	49.8

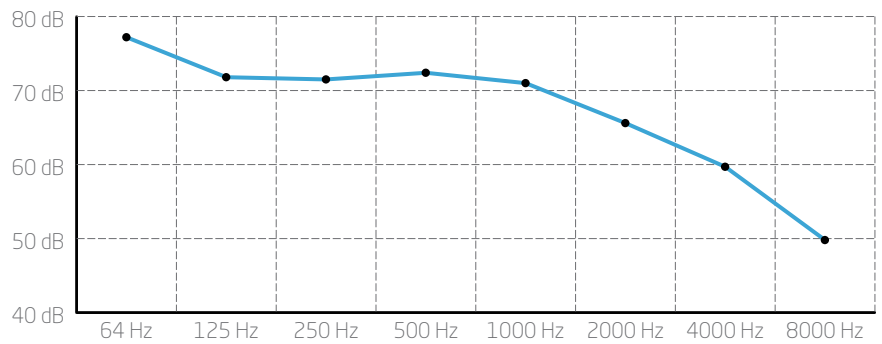

*Occupant at least 1.0 m from sound source.

Sound Pressure Curves

PHSE35

A Class: 75.2dB*

Frequency (Hz)	Decibel (dB)
64	79.5
125	77.2
250	76.1
500	72.6
1000	70.8
2000	64.8
4000	58.3
8000	52.9

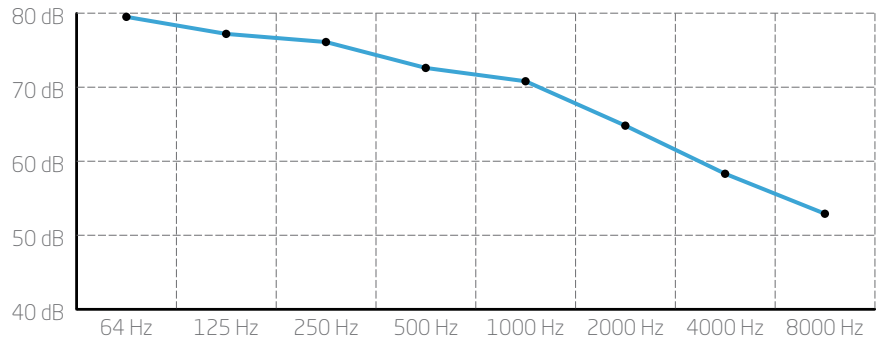

PHE40

A Class: 68.2dB*

Frequency (Hz)	Decibel (dB)
64	42
125	58
250	56
500	61
1000	64
2000	62
4000	60
8000	54

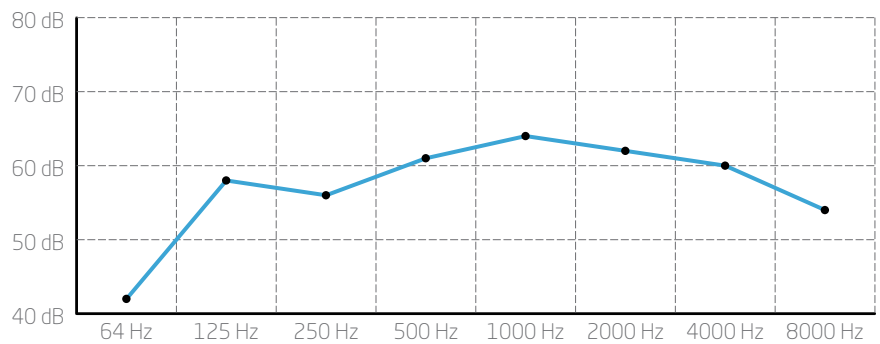

PHE45

A Class: 70.3dB*

Frequency (Hz)	Decibel (dB)
64	43
125	58
250	57
500	63
1000	66
2000	64
4000	62
8000	56

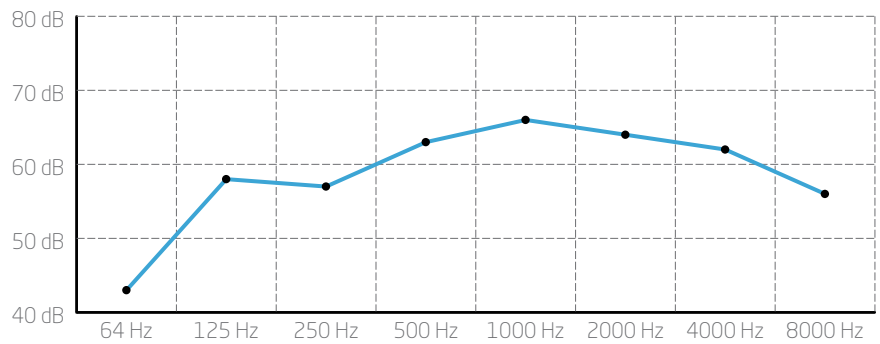

PHE50

A Class: 71.3dB*

Frequency (Hz)	Decibel (dB)
64	44
125	59
250	58
500	64
1000	67
2000	65
4000	63
8000	57

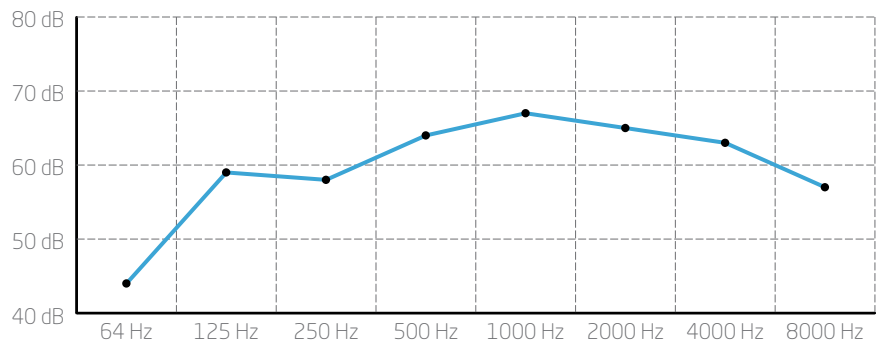

*Occupant at least 1.0 m from sound source.

PHE56 **A Class: 72.3dB***

Frequency (Hz)	Decibel (dB)
64	44
125	59
250	58
500	65
1000	68
2000	66
4000	64
8000	58

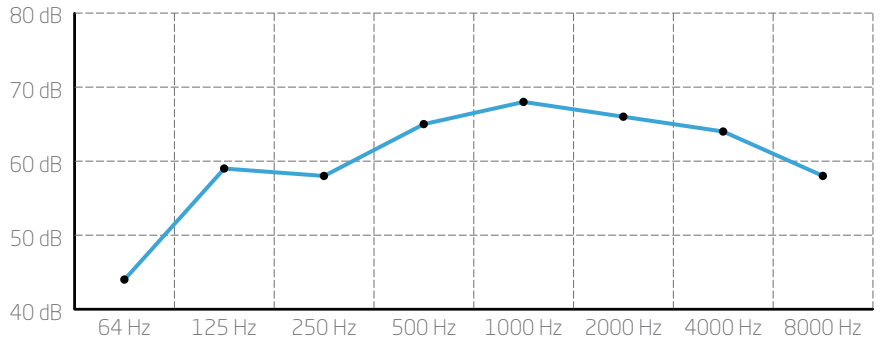

PHE66 **A Class: 71.2dB***

Frequency (Hz)	Decibel (dB)
64	45
125	56
250	59
500	68
1000	65
2000	65
4000	63
8000	56

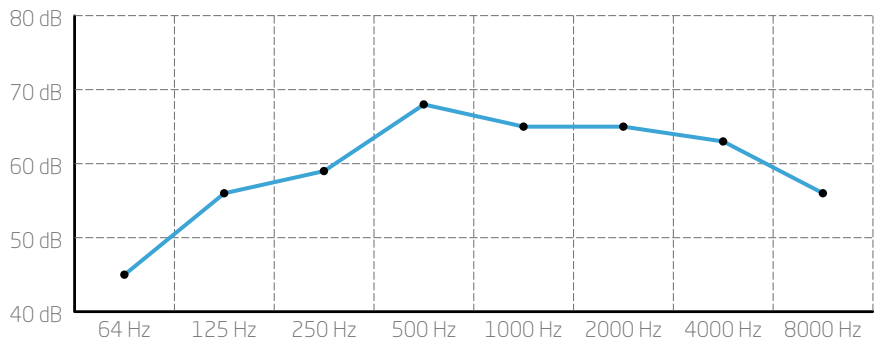

PHE73 **A Class: 73.0dB***

Frequency (Hz)	Decibel (dB)
64	46
125	57
250	60
500	69
1000	67
2000	67
4000	65
8000	58

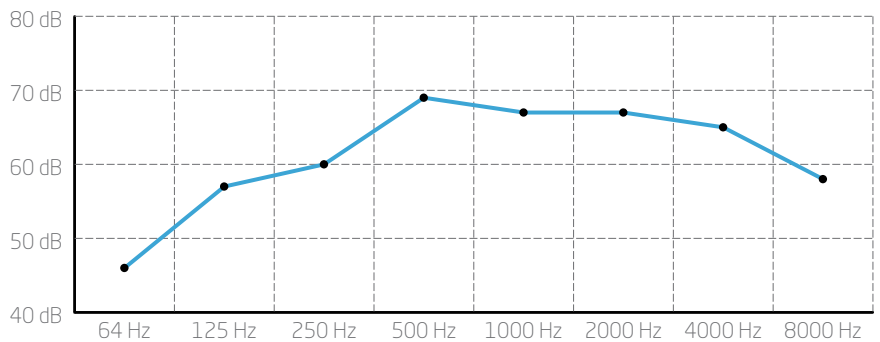

PHE80 **A Class: 75.8dB***

Frequency (Hz)	Decibel (dB)
64	47
125	59
250	62
500	71
1000	70
2000	70
4000	68
8000	61

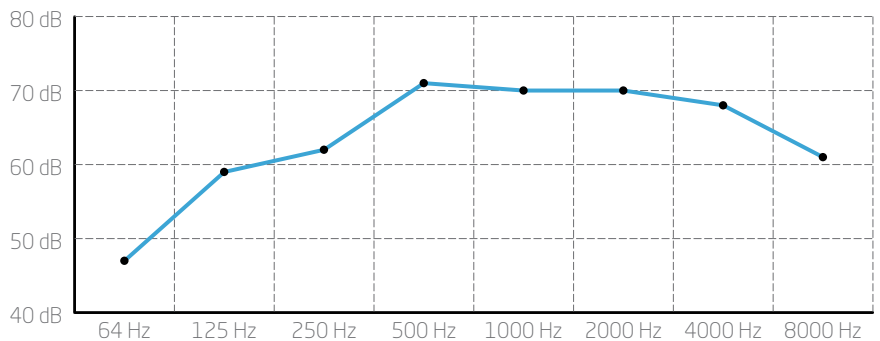

*Occupant at least 1.0 m from sound source.

Sound Pressure Curves

PHE85

A Class: 75.8dB*

Frequency (Hz)	Decibel (dB)
64	48
125	60
250	63
500	72
1000	71
2000	72
4000	69
8000	62

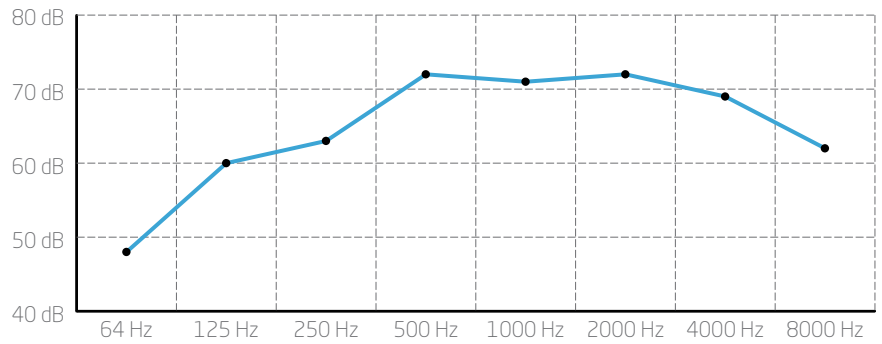

PHE90

A Class: 73.6dB*

Frequency (Hz)	Decibel (dB)
64	46
125	58
250	60
500	70
1000	67
2000	68
4000	65
8000	58

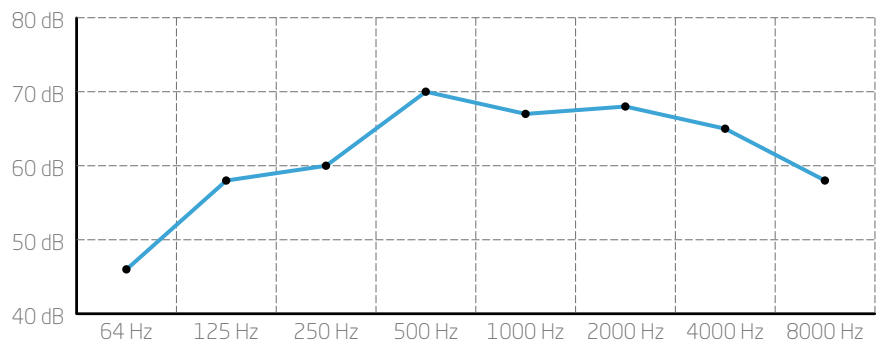

PHE95

A Class: 76.0dB*

Frequency (Hz)	Decibel (dB)
64	48
125	59
250	62
500	72
1000	70
2000	70
4000	68
8000	61

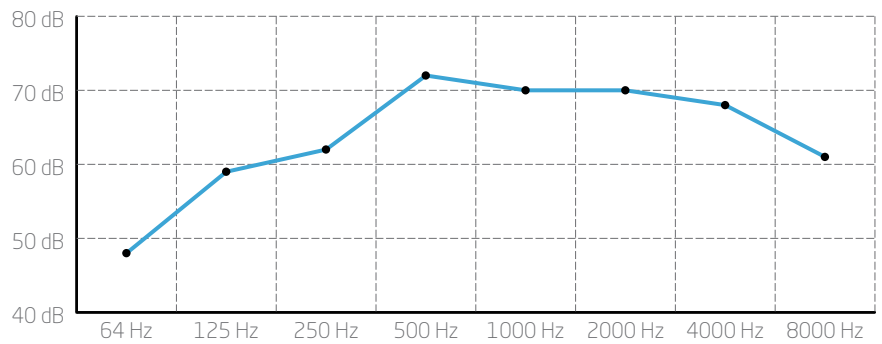

*Occupant at least 1.0 m from sound source.

PHE100 A Class: 77.0dB*

Frequency (Hz)	Decibel (dB)
64	50
125	61
250	64
500	73
1000	71
2000	71
4000	69
8000	62

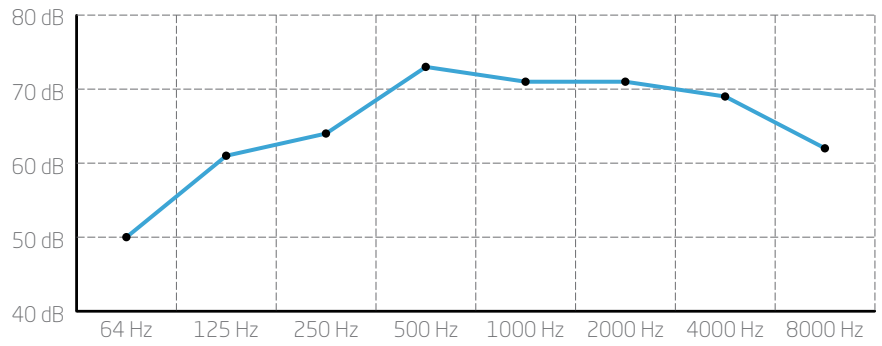

PHE120 A Class: 76.0dB*

Frequency (Hz)	Decibel (dB)
64	49
125	61
250	63
500	72
1000	70
2000	70
4000	68
8000	61

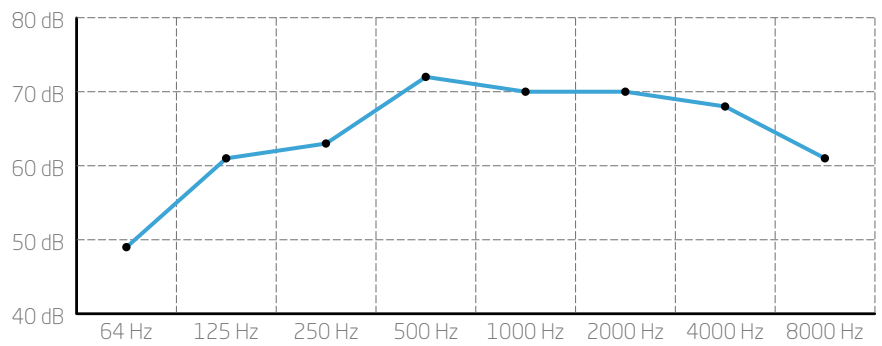

PHE140 A Class: 80.2dB*

Frequency (Hz)	Decibel (dB)
64	51
125	63
250	66
500	75
1000	74
2000	75
4000	72
8000	65

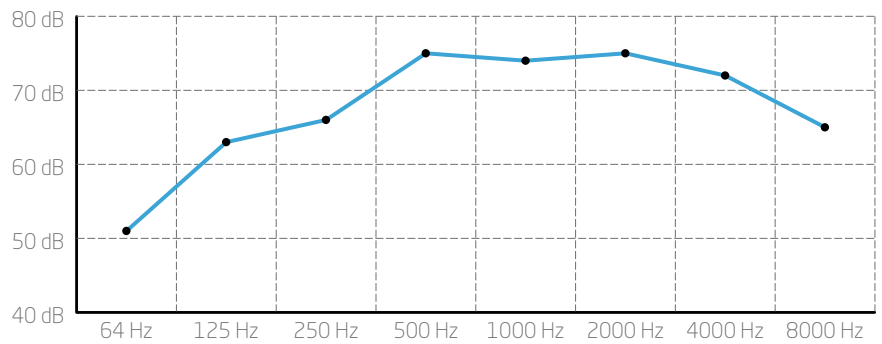

*Occupant at least 1.0 m from sound source.

Sound Pressure Curves

PHE160

A Class: 77.6dB*

Frequency (Hz)	Decibel (dB)
64	51
125	62
250	64
500	74
1000	71
2000	72
4000	69
8000	62

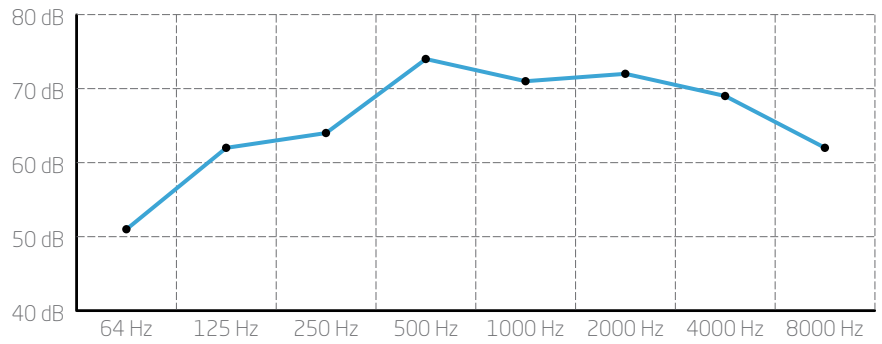

PHE180

A Class: 80.8dB*

Frequency (Hz)	Decibel (dB)
64	52
125	64
250	67
500	76
1000	75
2000	75
4000	73
8000	66

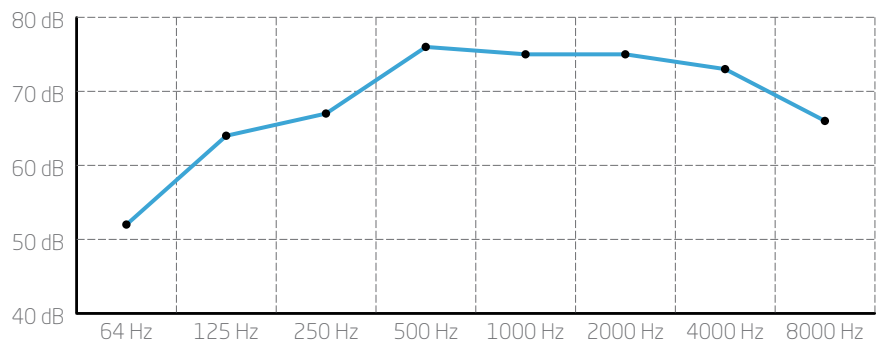

PHE200

A Class: 83.2dB*

Frequency (Hz)	Decibel (dB)
64	53
125	66
250	68
500	78
1000	77
2000	78
4000	75
8000	68

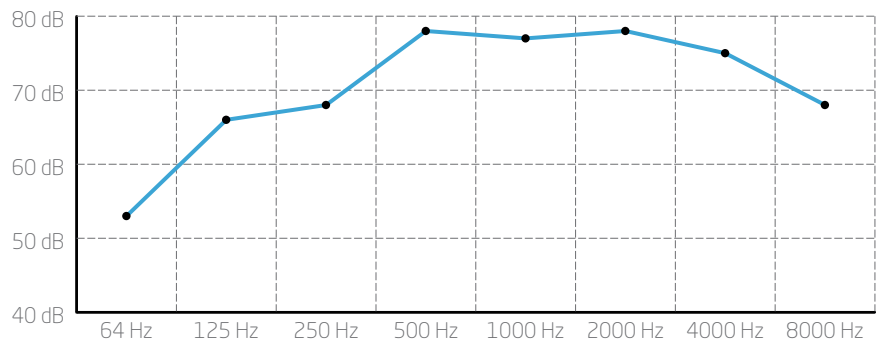

*Occupant at least 1.0 m from sound source.

Wiring Diagrams

PHSE8-10

1P
240V50HZ

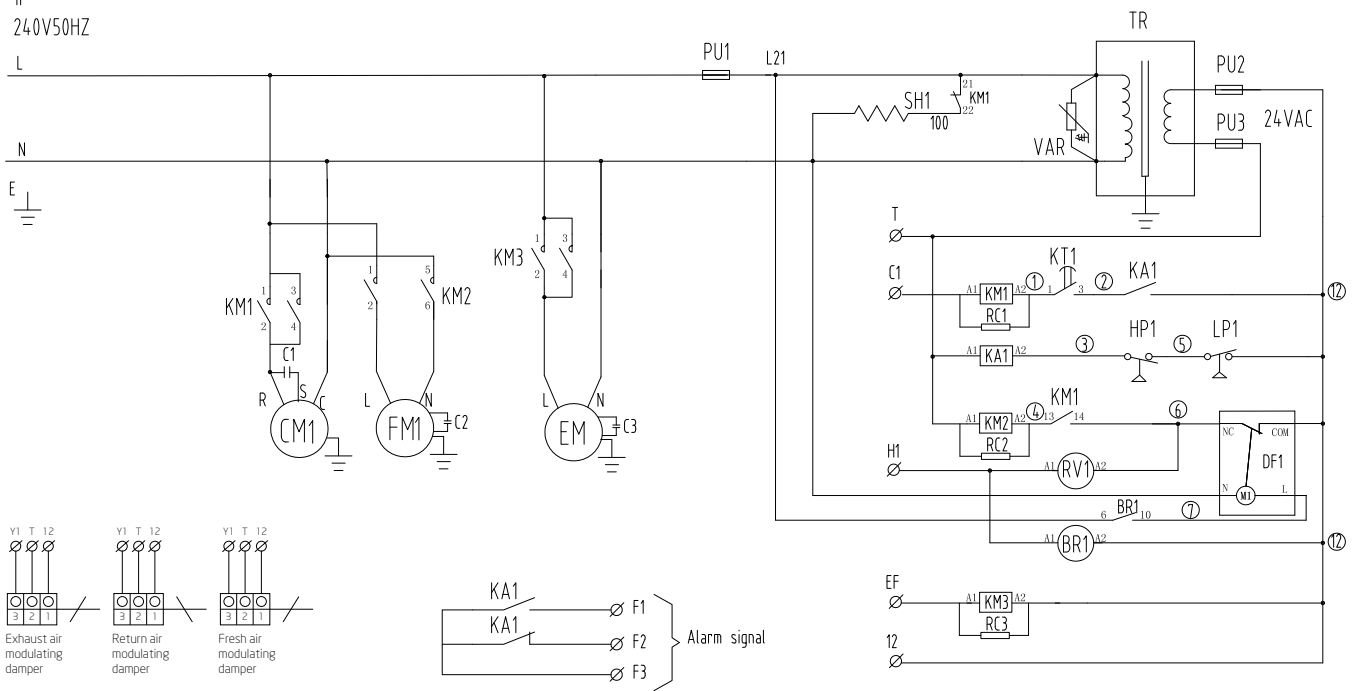

- | | | | | | | | |
|-------|-------------|------|-------------|-------|-----------------|-----|----------------|
| KM1-3 | Contactor | VAR | Varistor | RC1-3 | Filter | FM1 | Condenser fan |
| TR | Transformer | KT1 | Time Relay | RV1 | Reversing valve | EM | Evaporator fan |
| PU1-3 | Fuse | C1-3 | Capacitor | L/HP1 | HP/LP switch | SH1 | Sump heater |
| DF1 | De ice | KA1 | Fault Relay | CM1 | Compressor | BR1 | Bypass Relay |

Wiring Diagrams

PHSE12-25

Three phase five line
415V 50HZ 3P

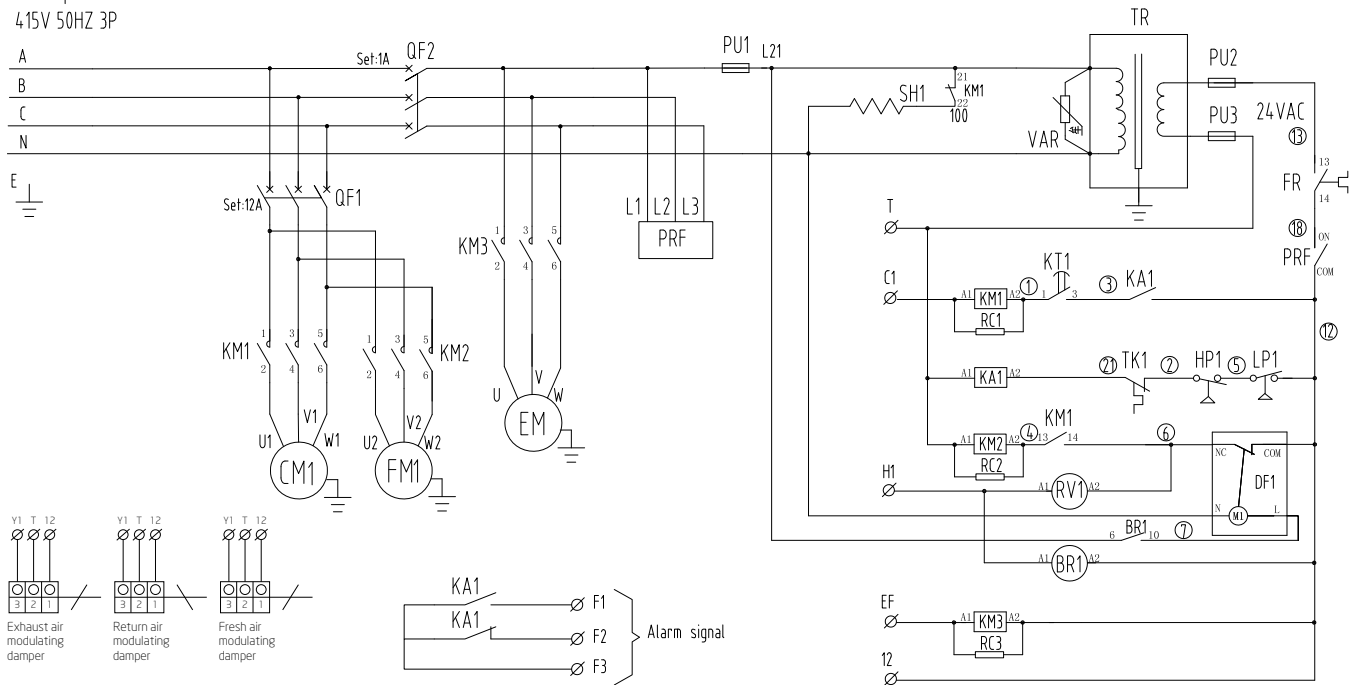

PHSE30-35

Three phase five line
415V 50HZ 3P

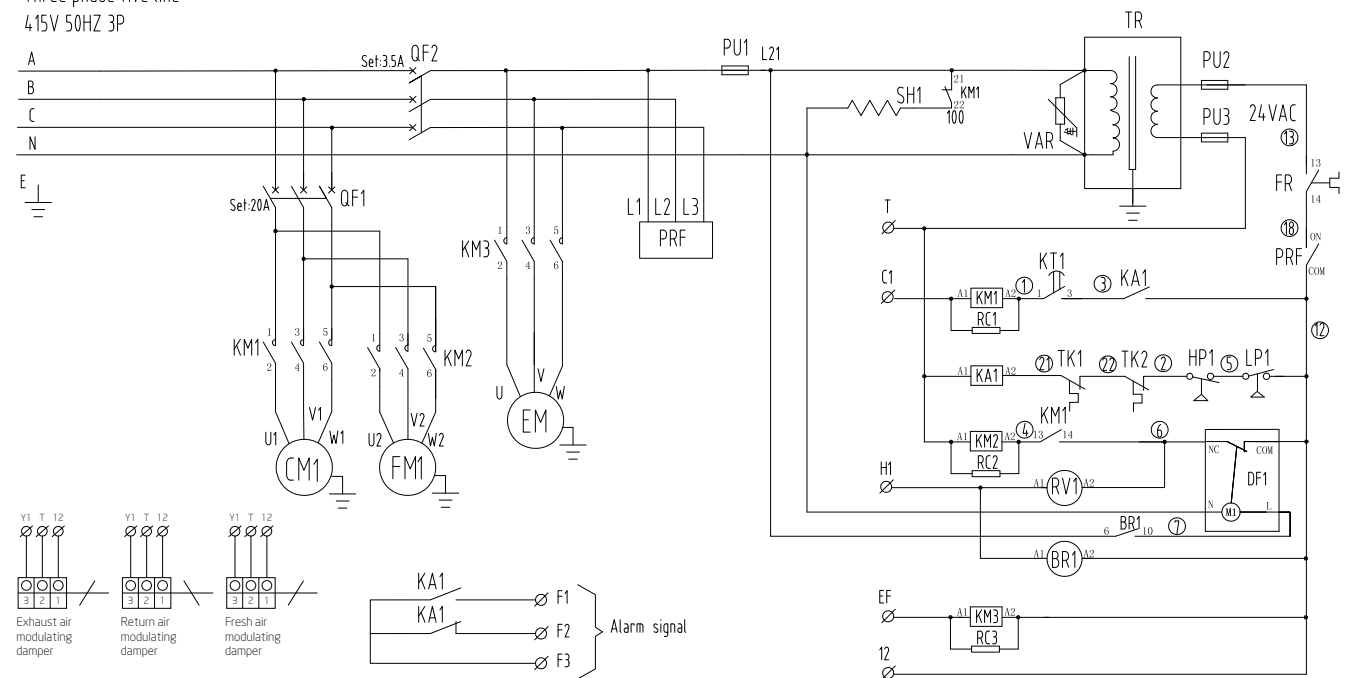

QF1-2	Motor Overload Breaker	DF1	De ice	RC1-3	Filter	CM1	Compressor
KM1-3	Contactor	VAR	Varistor	RV1	Reversing valve	FM1	Condenser fan
FR	Thermal Relay	KT1	Time Relay	TK1	Overload protector	EM	Evaporator fan
TR	Transformer	PRF	Phase protection	TK2	Disch. temp. sensor	SH1	Sump heater
PU1-3	Fuse	KA1	Fault Relay	L/HP1	HP/LP switch	BR1	Bypass Relay

PHE40-66

Three phase five line
415V 50HZ 3P

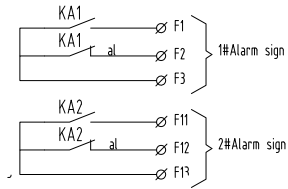
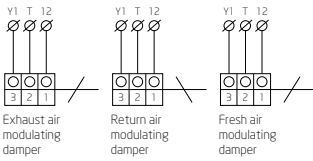
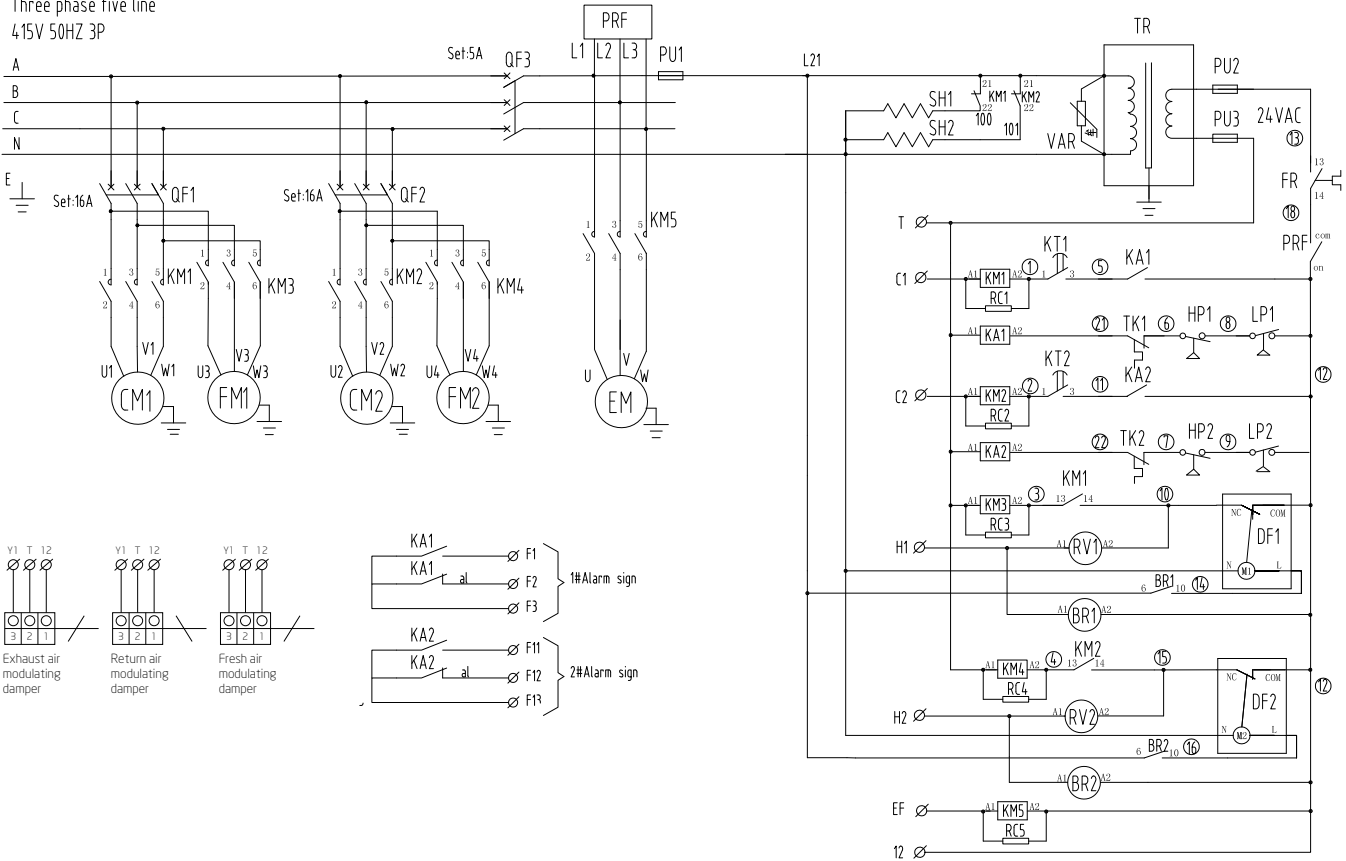

- | | | | | | | | |
|-------|------------------------|-------|------------------|---------|-----------------|---------|----------------|
| QF1-3 | Motor Overload Breaker | DF1-2 | De ice | RC1-5 | Filter | FM1/FM2 | Condenser fan |
| KM1-5 | Contactor | VAR | Varistor | RV1-2 | Reversing valve | EM | Evaporator fan |
| FR | Thermal Relay | KT1-2 | Time Relay | L/HP1-2 | HP/LP switch | SH1-2 | Sump heater |
| TR | Transformer | PRF | Phase protection | CM1-2 | Compressor | BR1-2 | Bypass Relay |
| PU1-3 | Fuse | KA1-2 | Fault Relay | | | | |

Wiring Diagrams

PH73-95

Three phase five line
415V 50HZ 3P

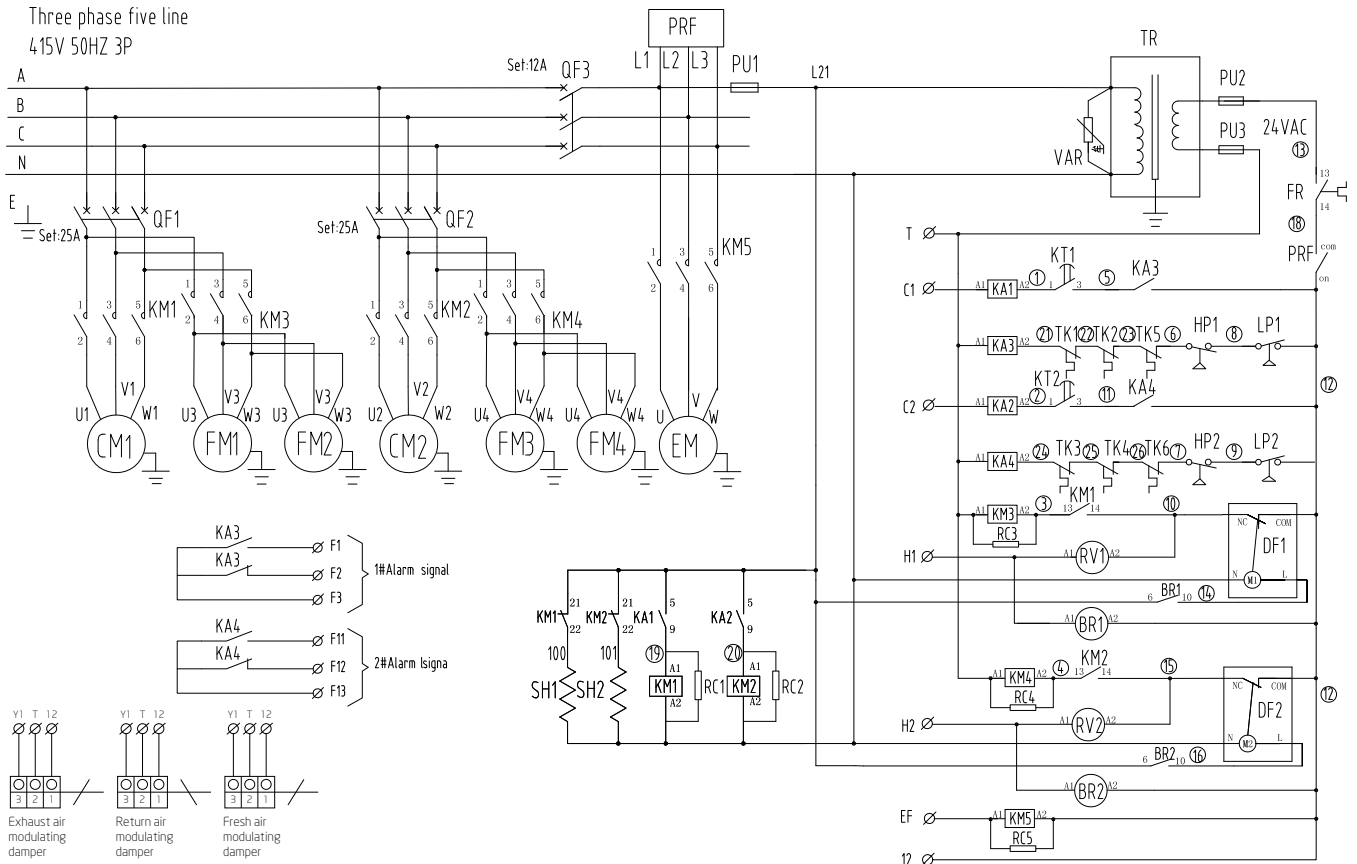

- QF1-3 Motor Overload Breaker
- KM1-5 Contactor
- FR Thermal Relay
- TR Transformer
- PU1-3 Fuse
- DF1-2 De ice
- VAR Varistor
- KT1-2 Time Relay
- PRF Phase protection
- KA1-2 Intermediate relay
- KA3-4 Fault Relay

- RC1-5 Filter
- RV1-2 Reversing valve
- TK1-4 Overload protector
- TK5-6 Disch. temp. protector
- L/HP1-2 HP/LP switch
- CM1-2 Compressor
- FM1-2 Condenser fan
- EM Evaporator fan
- SH1 Sump heater
- BR1 Bypass Relay

PHE100-140

Three phase five line
415V 50HZ 3P

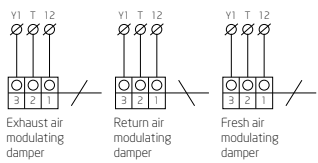
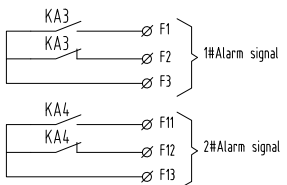
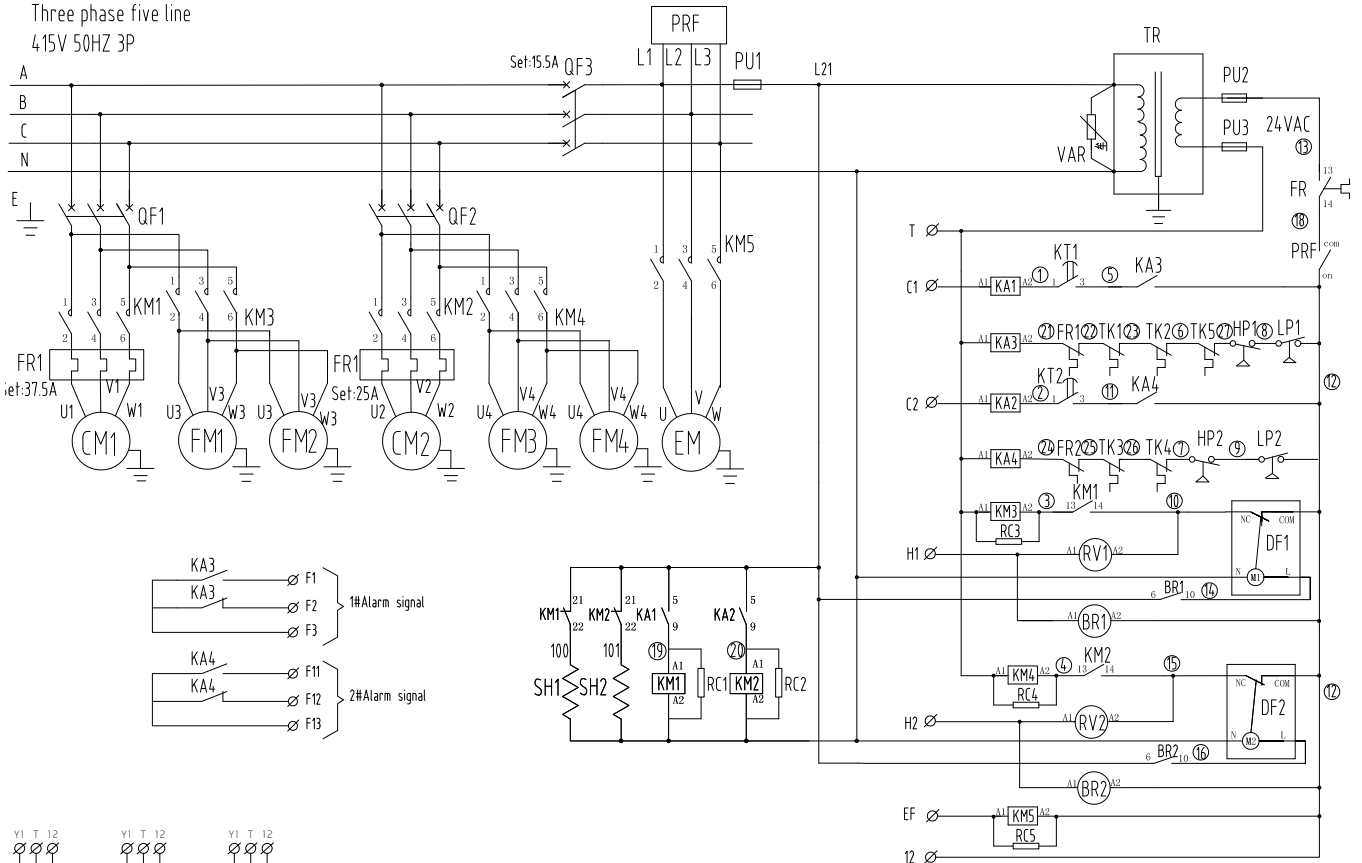

SY240/SZ161 Overload Protector inner compressor

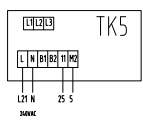

- | | | | |
|-------|------------------------|---------|--------------------|
| QF1-3 | Motor Overload Breaker | RC1-5 | Filter |
| KM1-5 | Contactor | RV1-2 | Reversing valve |
| FR | Thermal Relay | TK1-4 | Overload protector |
| TR | Transformer | TK5 | Compressor protect |
| PU1-3 | Fuse | L/HP1-2 | HP/LP switch |
| DF1-2 | De ice | CM1-2 | Compressor |
| VAR | Varistor | FM1-2 | Condenser fan |
| KT1-2 | Time Relay | EM | Evaporator fan |
| PRF | Phase protection | SH1 | Sump heater |
| KA1-2 | Intermediate relay | BR1 | Bypass Relay |
| KA3-4 | Fault Relay | | |

Wiring Diagrams

PHE160-200

Three phase five line
415V 50HZ 3P

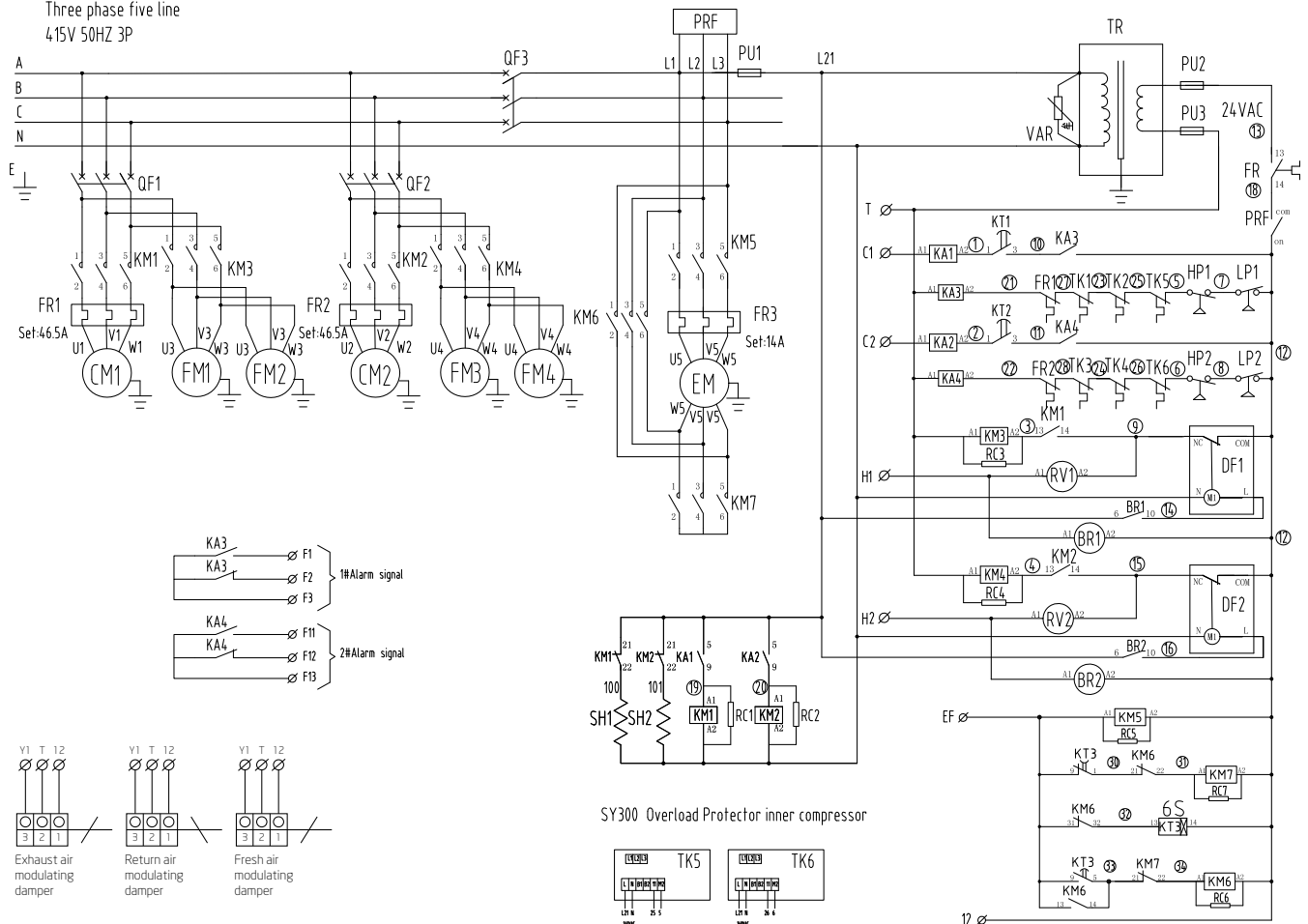

- QF1-3 Motor Overload Breaker
- KM1-7 Contactor
- FR1-3 Thermal Relay
- TR Transformer
- PU1-3 Fuse
- DF1-2 De ice
- VAR Varistor
- KT1-2 Time Relay
- PRF Phase protection
- KA1-2 Intermediate relay
- KA3-4 Fault Relay

- RC1-7 Filter
- RV1-2 Reversing valve
- TK1-4 Overload protector
- TK5-6 Disch. temp. sensor
- L/HP1-2 HP/LP switch
- CM1-2 Compressor
- FM1-4 Condenser fan
- EM Evaporator fan
- SH1-2 Sump heater
- BR1-2 Bypass Relay





DUNNAIR (Aust) Pty Ltd

Head Office:

Ashford Avenue, Milperra NSW 2214

P 02 8774 1400

F 02 8774 1490

E dunnsales1@airchange.com.au

W www.dunnair.com.au

Dunnair Victoria:

P 03 9482 1010

F 03 9482 4410

E dunnsales3@airchange.com.au

Dunnair Queensland:

P 07 3891 1974

F 07 3891 1991

E dunnsales2@airchange.com.au

Dunnair (Aust) Pty Ltd supports a policy of continuous product improvement. Therefore specification and designs are subject to change without prior notice. Dunnair (Aust) Pty Ltd accepts no responsibility for possible errors in Catalogues, brochures and other printed material. Dunnair is part of the Air Change Group of companies.



www.dunnair.com.au