



# AIR*Cooled*

Split Ducted Air Conditioners 6 kW to 200 kW



# Dunnair

## Quality Engineering Solutions

Dunnair is now firmly positioned as a leading supplier to the air conditioning industry.

The name Dunnair is synonymous with high quality products in the commercial air-conditioning industry. Beginning with Dunn Air Conditioning in 1961 and more recently, Dunnair International and Dunnair Australia, the company continues to be a leading supplier of air-conditioning units for the Australian market.

In 1994, the company was bought by Multistack and renamed Dunnair International. In 2004, Ernest Ugazio acquired the sales and subsequently state service department of Dunnair. This led to the company being divided into separate entities: Dunnair International and Dunnair Australia, the former focused on Multistack Chiller sales and spare parts; while the latter began design and development of a split ducted and rooftop packaged range that was manufactured in China. More recently, in April 2018, Air Change Group acquired Dunnair Australia, solidifying Dunnair's position as a manufacturer of high quality, specified air conditioning units.

The **Air Cooled series of split ducted units** shown in this brochure are part of Dunnair's range of high quality units for every application. Dunnair has also become the first choice when individual engineering solutions are required. Fast-moving and responsive, Dunnair supplies made-to-measure HVAC solutions to a growing number of high profile developments across Australia.

Dunnair research and development plus a strict quality control program have been fundamental to our growth, success and reputation. Dunnair units are manufactured in accordance with strict quality control standards and are MEPS rated and developed for Australian conditions.

**Range:** Dunnair's modern factories manufacture 16 separate product lines and some 600 different models. Dunnair can supply most products the HVAC industry requires. The recent acquisition by Air Change, a company known for its award winning innovation, is proof that the company is working continuously to improve its product range and the efficiency of its products.

**Specialised Solutions:** Dunnair will engineer and manufacture equipment to suit the application and building design. No challenge will go unaccepted. We will design and make special products as required for the building, mining, transport and maritime industry. We employ mechanical engineers in all sales offices in Australia. Their role is to supporting designers to achieve their goals.

Our promise to system designers is: **"Tell us what you need and we will work with you to deliver".**

With a head office in Sydney, Dunnair also has offices in Victoria and Queensland. Dunnair maintains a dedicated engineering and sales support staff waiting to assist you with technical and product information and provide valuable solutions for your project.

**Dunnair will design, build and deliver HVAC equipment to meet the most stringent specifications and difficult applications.**

**"We make special equipment."**



## Features

- SHS6 to 35 single stage
- SH40 to 200 two stage
- Optional two stage available for 18kW to 35kW
- SHS6 to 35 direct drive
- SH40 to 200 belt drive
- Automatic De-Ice
- Liquid Accumulator
- Dry Filter
- Crankcase heater
- 24 volt control
- Galvanised steel panelling
- Durable powder coated cabinet (outdoor unit)
- External stainless steel fittings
- Easy access panels with turn lock handles, no screws
- 25 mm insulation
- Coil corrosion protection
- High quality scroll compressors
- High/low pressure protection for compressor
- Time delay protection for compressor
- Limit start timer
- Quiet & efficient
- Independent defrost dual circuit units for two stage units
- Phase reverse protection
- Optional electric reheat high temperature protection
- Overload protection for both indoor and outdoor fan motor
- MEPS rated
- Manufactured for Australian Standards & Conditions
- High quality control procedures
- R410a refrigerant is used in standard units. Units with R407c refrigerant are available on request

# Optional Features

As an active market player in the commercial air conditioning industry, we understand that every project is unique. Standard manufactured units may not meet the requirements of your system design.

Dunnair always welcome enquiries for custom made air conditioning equipment.

Available options are listed below:

- Stainless steel condensate tray
- 50mm insulation
- Electric heating fitted to cooling-only models
- Higher external static pressure up to 500 pa
- Two stages or more dependent on unit size
- Belt drive instead of direct drive fan
- Copper fins
- Vertical fan coil units
- EC motor
- EC plug fan
- Other Customised options available. Please contact your local Dunnair sales office



# Optional Controller

## DAT - 770 multifunction thermostat

Technologically advanced in design and performance, the DAT - 770 is the ideal thermostat control for any installation of air conditioning systems.

### Features include:

- Auto season change over
- Select programmable or manual mode
- Heat cool or heat pump (O/B) logic
- 0-10 V output option for heating or cooling
- High & Low balance points
- Single or three-speed fan control
- Keyboard and/or temperature locks
- Occupancy sensor inputs
- Programmable occupancy inputs
- Adaptive recovery (Optimised start)
- Smart fan logic for commercial control



- PIN protected menus (installer PIN)
- Outside air temperature display
- 24 V powered with memory backup
- Volt free (clean contact) relays
- Large backlit EL display
- Remote temperature sensors available
- Integrated Modbus option
- Replaces most 24 V thermostats

# Specifications

## Models SHS6 – SH200

Model	Capacities (kW)			Nominal Levels		Power Phase	Unit Noise Levels (dBA)		Fan Drive	Refrigerant Circuits
	Total Cooling	Sensible Cooling	Heating	Air Flow (L/s)	Max Current (A)		Indoor	Outdoor		
SHS6	5.8	5	5.7	361	11.2	1	47.8	55.5	Direct	1
SHS8	7.8	7.2	7.6	467	10.4		46.5	56.4		
SHS10	9.8	8	10.1	611	20.8		48.6	56.7		
SHS12	12.2	9.9	12.6	695	14	3	68.4	57.5		
SHS15	14.3	13	14.2	840	13.9		61.8	58.2		
SHS18	17.2	14.4	17.4	928	16		63.7	59.8		
SHS20	19.6	15.7	19.3	1030	17		70.5	73.7		
SHS25	24.2	19.3	24.5	1390	22.4		71	74.9		
SHS30	30.6	25.4	30.6	1800	25.9		69.8	75.5		
SHS35	34.8	28.8	32.4	2000	27.6		70.3	75.3		
SH40	39.1	32.6	38	2200	30.8		71.4	75.7	Belt	2
SH45	44.4	36.8	43.5	2700	37.2		72.2	76.2		
SH50	48.6	39.8	44.2	2800	41.2		72.8	76.7		
SH56	55.6	45	57.4	3000	47.7	72.8	77.1			
SH66	65.5	50.9	60.7	3500	54.5	73.1	77.7			
SH73	72.8	59.3	66.6	3900	60.6	73.7	78.4			
SH80	80.4	65.5	80.7	4300	66.2	74.6	79			
SH90	88.5	71	85	4800	74.4	75.5	79.6			
SH100	102.2	82.9	98.5	5500	85.2	77	80.6			
SH120	117.6	95.2	116.2	6500	98.8	77.1	82.2			
SH140	137.8	110.6	132	7500	117.5	77.7	83.3			
SH160	156.2	127.5	152.5	8500	133.9	80.1	83.7			
SH180	176.8	143.6	169.4	9500	153.2	82.5	85.4			
SH200	201.8	164.3	196.2	10500	163.7	82.6	87.2			

Cooling Capacity is based on DB 27°C, 19°C WB Entering Air Temperature & 35°C Ambient Temperature

Heating Capacity is based on 21°C DB, Entering Air Temperature

Sound Levels are measured from 1 m of the unit

# Dimensions

## Models PHS8-PH200

Model	Outdoor Unit		Indoor Unit	
	Length x Width x Height (mm)	Weight (kg)	Length x Width x Height (mm)	Weight (kg)
SHS6	860 x 310 x 718	65	850 x 620 x 400	50
SHS8	950 x 340 x 840	77	1100 x 620 x 400	56
SHS10	950 x 340 x 840	82	1100 x 620 x 400	58
SHS12	950 x 350 x 950	89	1250 x 620 x 400	65
SHS15	950 x 340 x 1245	105	1400 x 620 x 420	80
SHS18	950 x 340 x 1230	105	1550 x 620 x 420	86
SHS20	950 x 340 x 1230	122	1600 x 620 x 420	90
SHS25	1300 x 950 x 700	241	1650 x 720 x 485	121
SHS30	1300 x 950 x 930	276	1900 x 720 x 485	132
SHS35	1300 x 1000 x 930	282	2100 x 720 x 485	140
SH40	1550 x 1200 x 900	360	1300 x 1200 x 940	220
SH45	1550 x 1400 x 900	365	1500 x 1200 x 940	240
SH50	1800 x 1755 x 910	530	1600 x 1200 x 940	290
SH56	1800 x 1755 x 910	532	1600 x 1200 x 940	290
SH66	1800 x 1755 x 910	535	2000 x 1250 x 1040	410
SH73	1800 x 1755 x 910	538	2000 x 1250 x 1040	412
SH80	1800 x 1803 x 910	615	2200 x 1250 x 1040	485
SH90	1800 x 2080 x 1100	710	2430 x 1350 x 1140	516
SH100	2050 x 2050 x 1350	1100	2150 x 1450 x 1350	620
SH120	2050 x 2050 x 1350	1170	2300 x 1550 x 1550	660
SH140	2050 x 2050 x 1750	1180	2650 x 1600 x 1550	730
SH160	2050 x 2050 x 1750	1250	2850 x 1800 x 1550	760
SH180	2150 x 2200 x 2350	1340	3050 x 1850 x 1650	820
SH200	2150 x 2150 x 2350	1400	3050 x 1850 x 1650	860

# Fan Curves

## Air Handling Performance

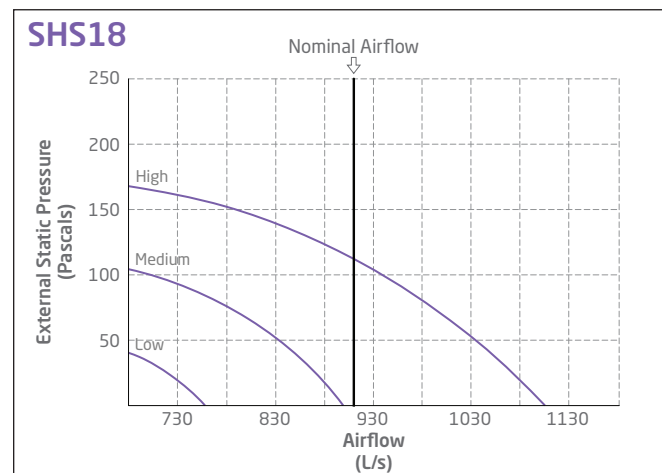
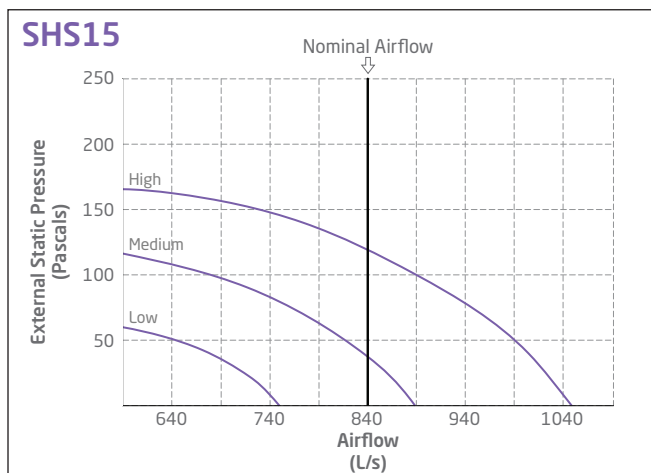
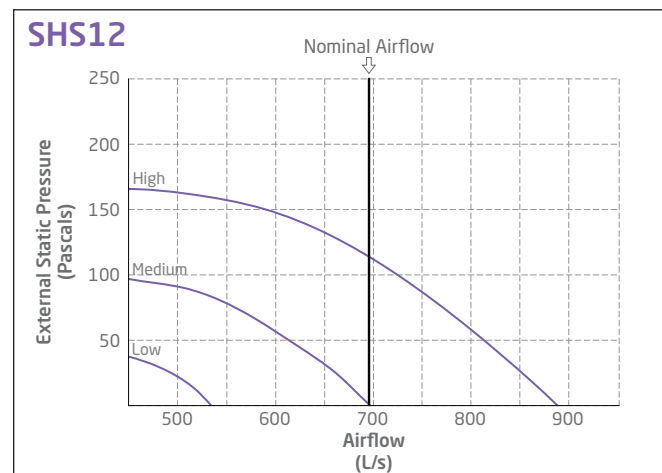
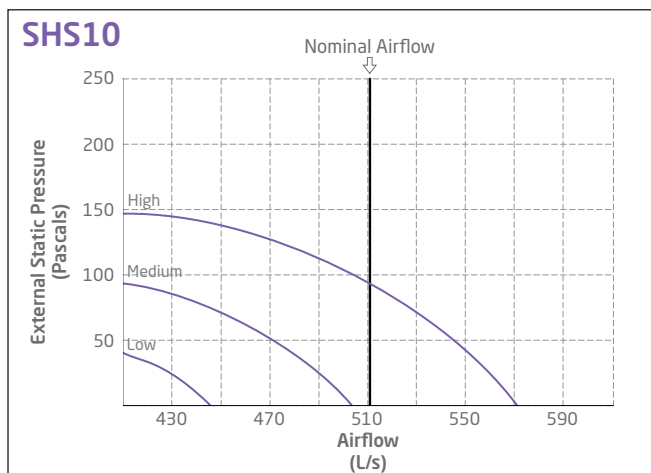
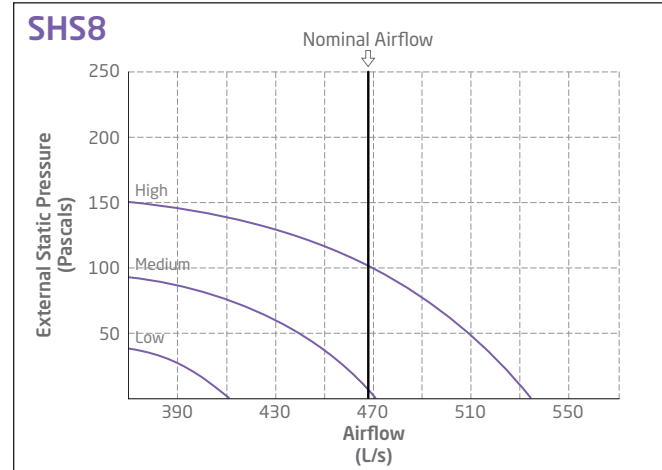
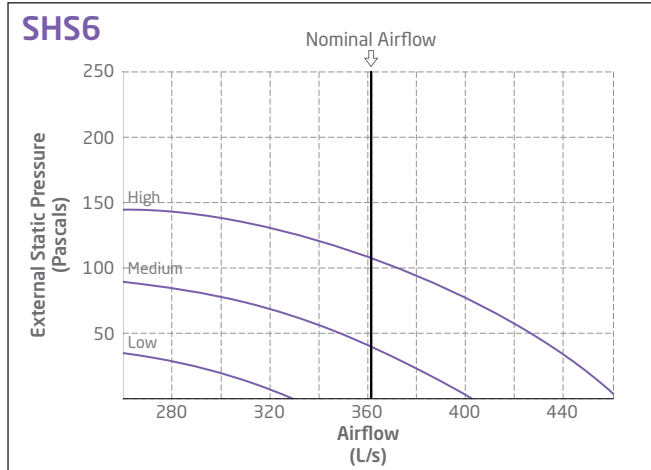

# Fan Curves

## Air Handling Performance

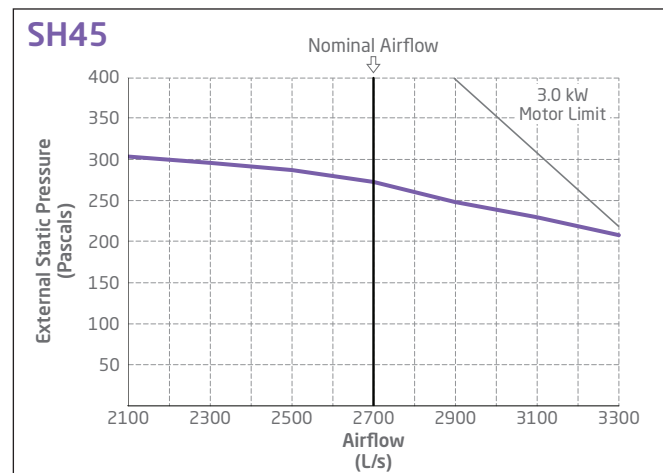
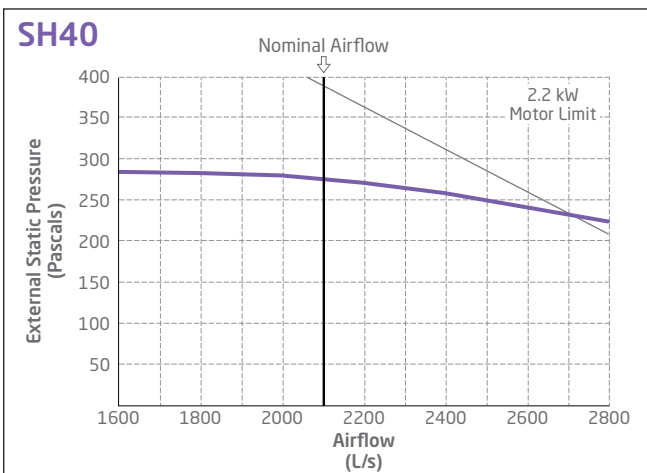
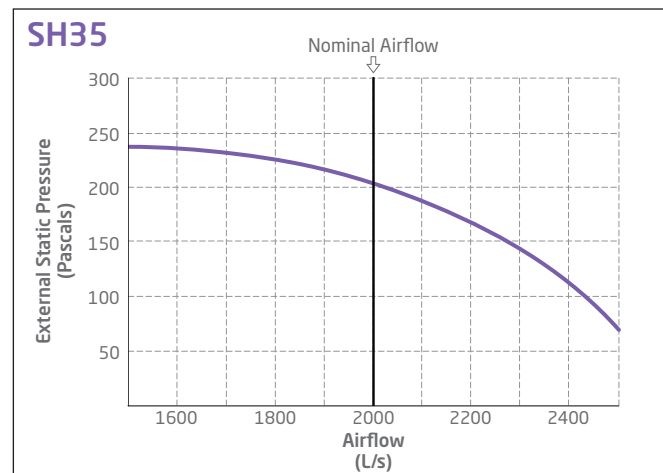
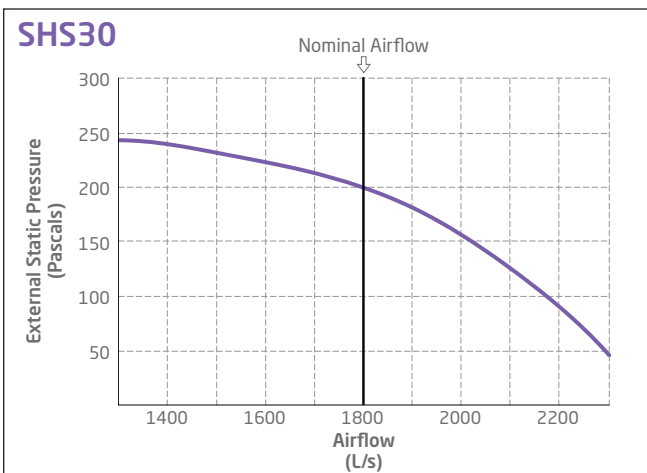
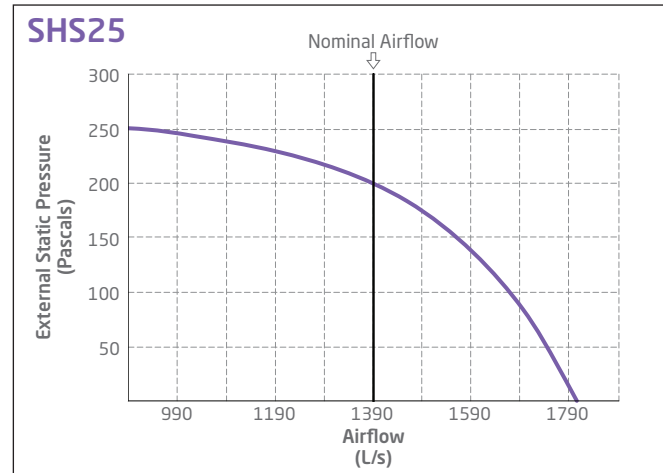
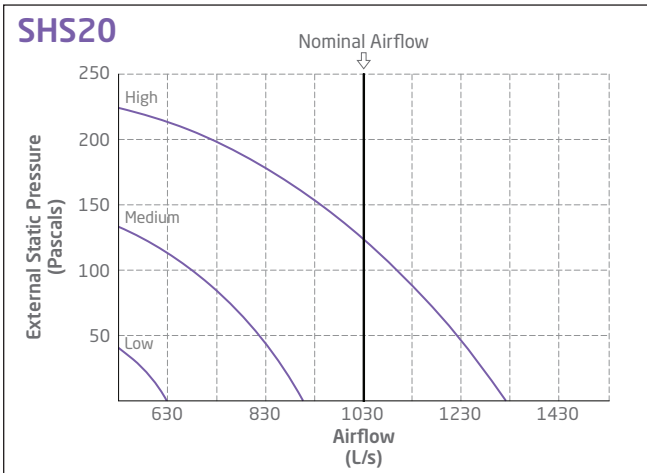



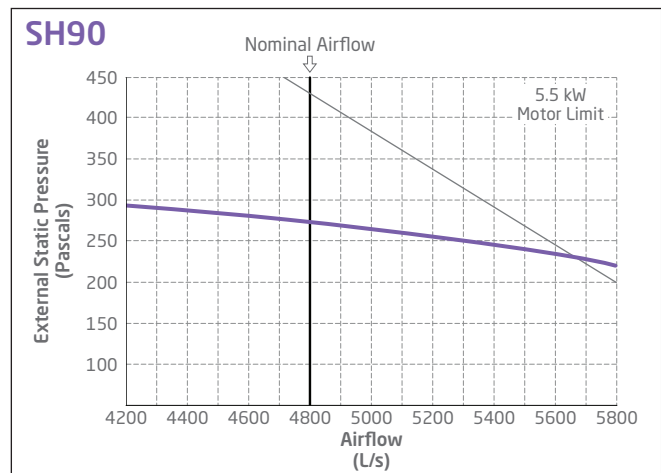
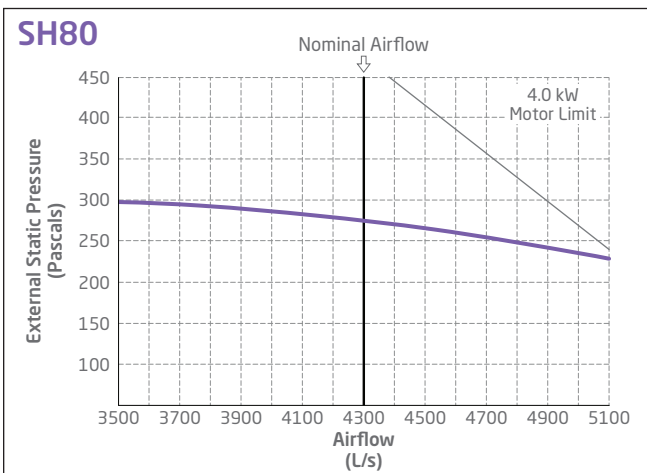
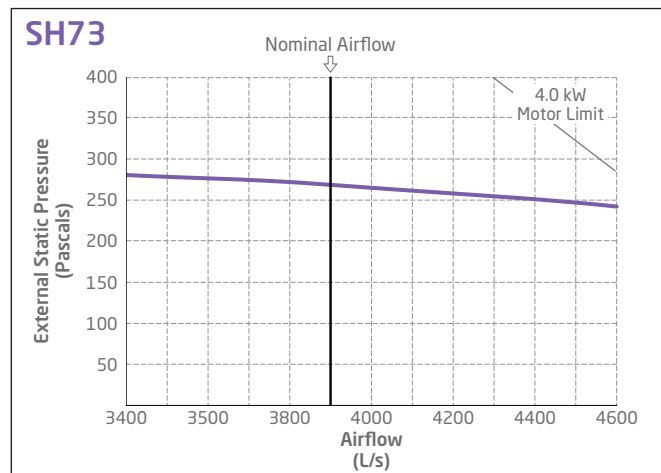
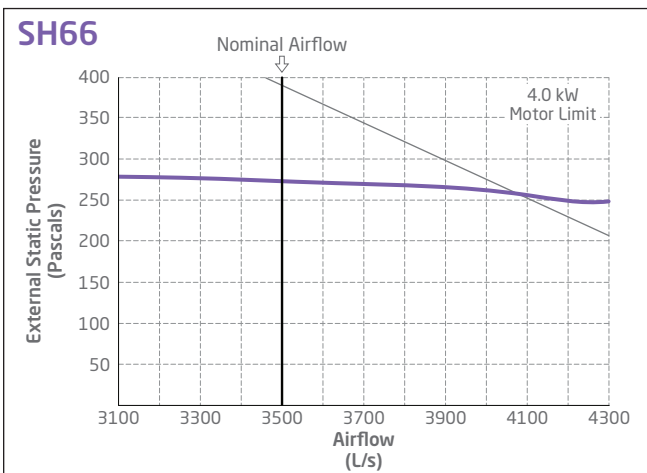
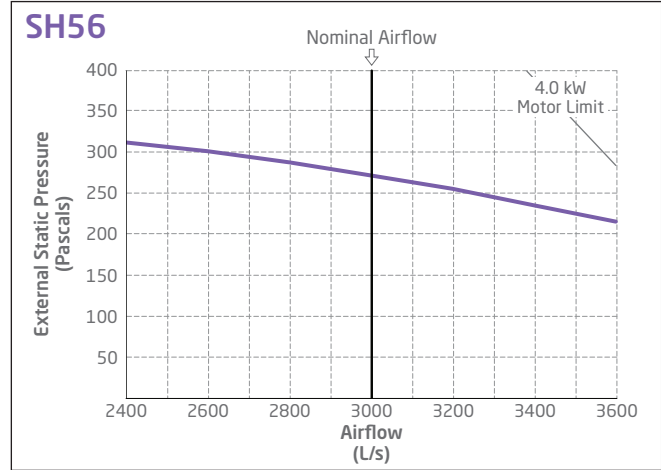
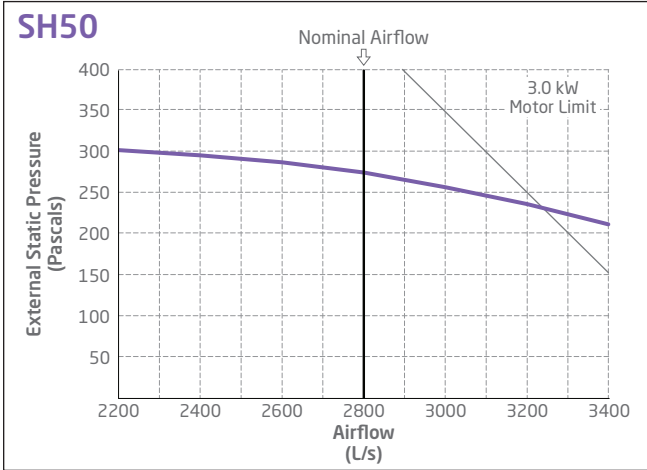

# Fan Curves

## Air Handling Performance

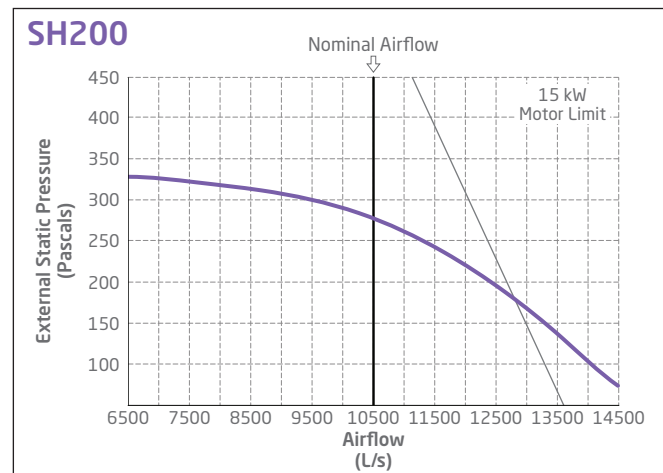
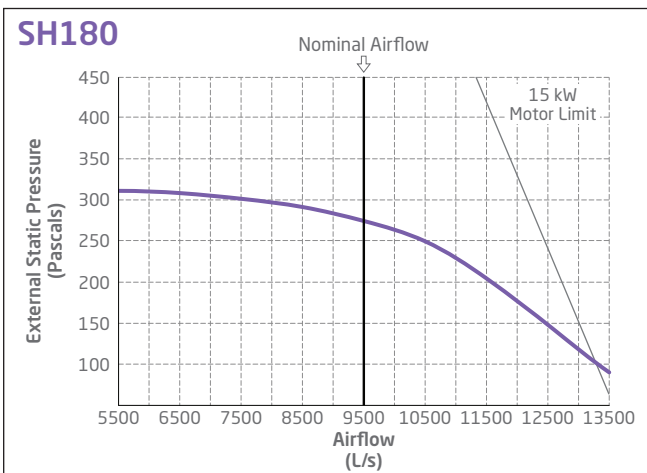
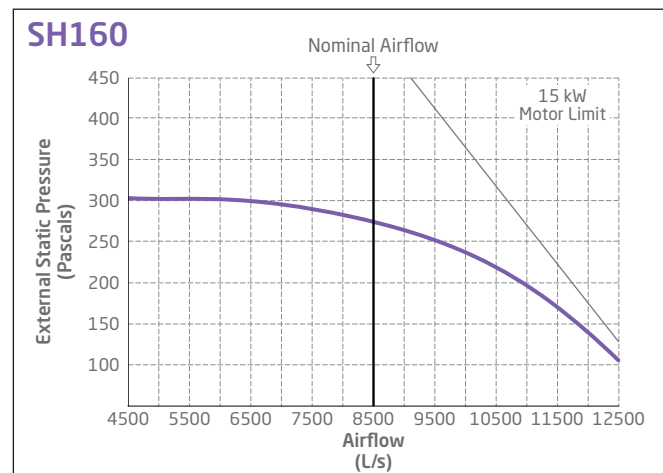
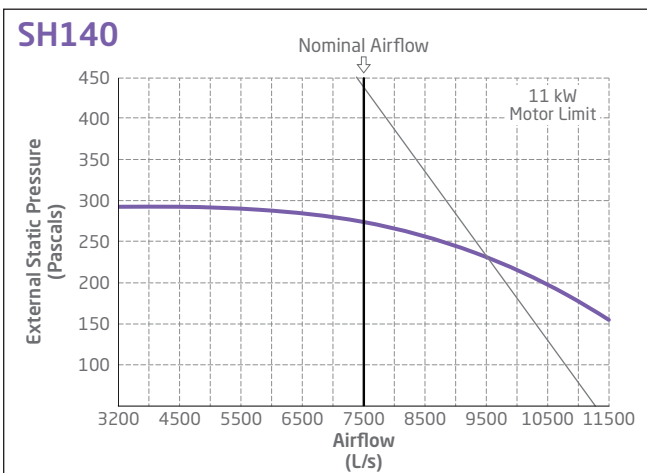
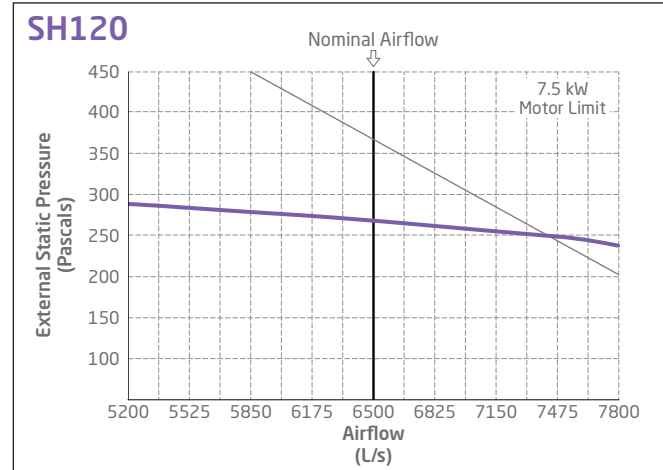
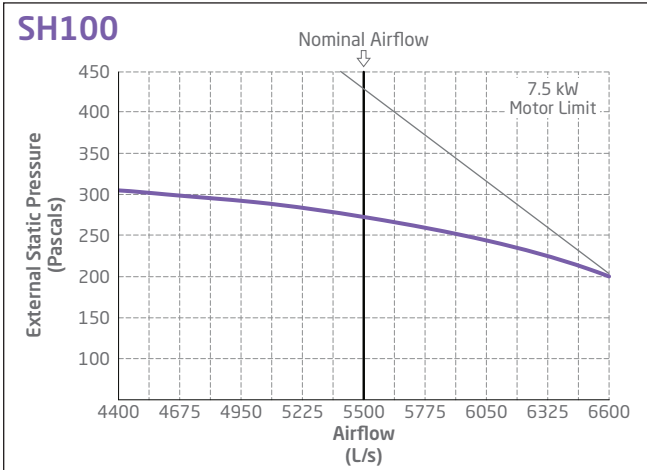

# Wiring Diagrams

## SHS6-10

1P  
240V/50HZ

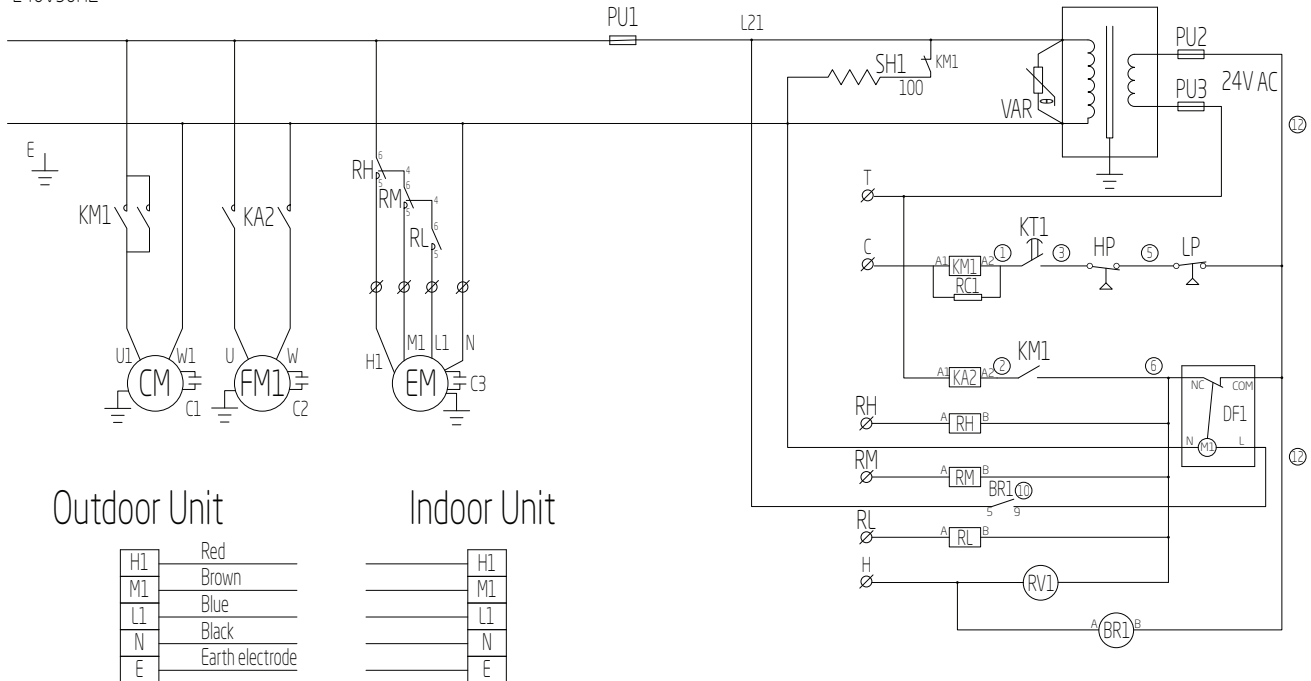

## SHS12-20

1P  
240V/50HZ

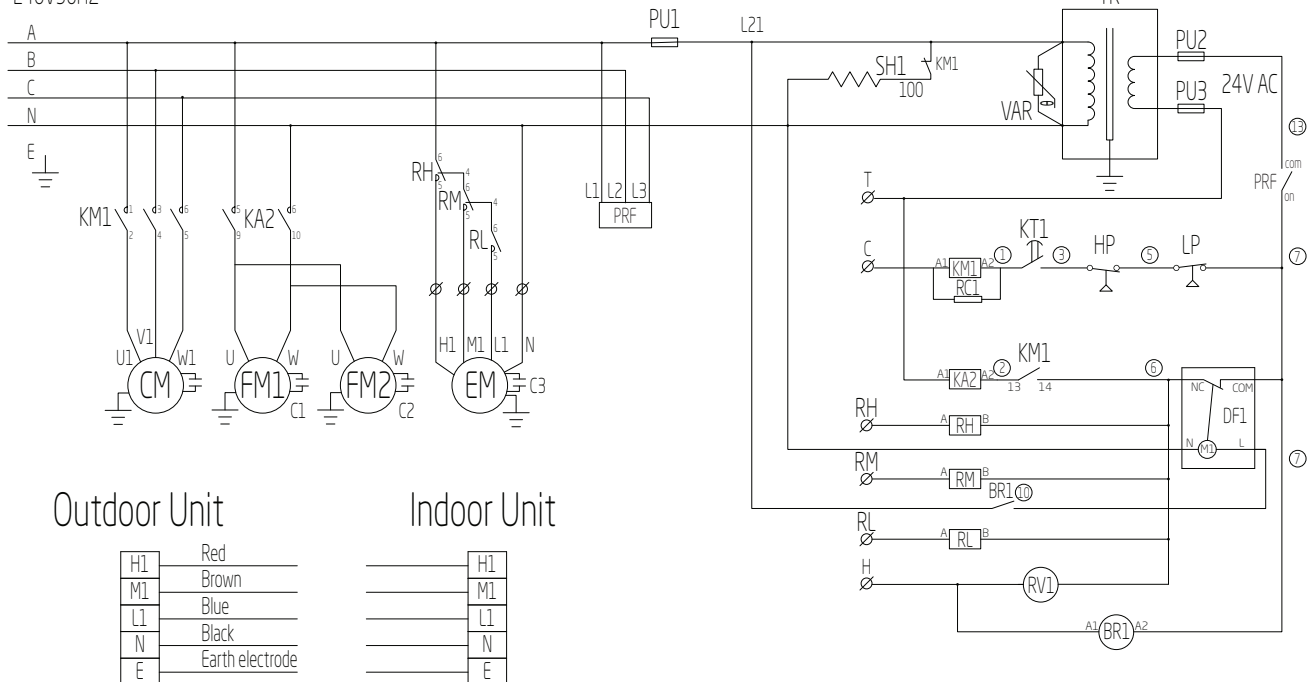

- |         |                  |       |             |       |                 |     |              |
|---------|------------------|-------|-------------|-------|-----------------|-----|--------------|
| KM1-3   | Contactors       | VAR   | Varistor    | RV1   | Reversing valve | SH1 | Sump heater  |
| TR      | Transformer      | KT1   | Time Relay  | HP/LP | HP/LP switch    | BR1 | Bypass Relay |
| PU1/2/3 | Fuse             | C1-3  | Capacitor   | CM1   | Compressor      |     |              |
| PRF     | Phase Protection | KA1   | Fault Relay | FM1   | Condenser fan   |     |              |
| DF1     | De ice           | RC1-3 | Filter      | EM    | Evaporator fan  |     |              |

# Wiring Diagrams

## SHS25-35

Three phase five line  
415V 50Hz 3P

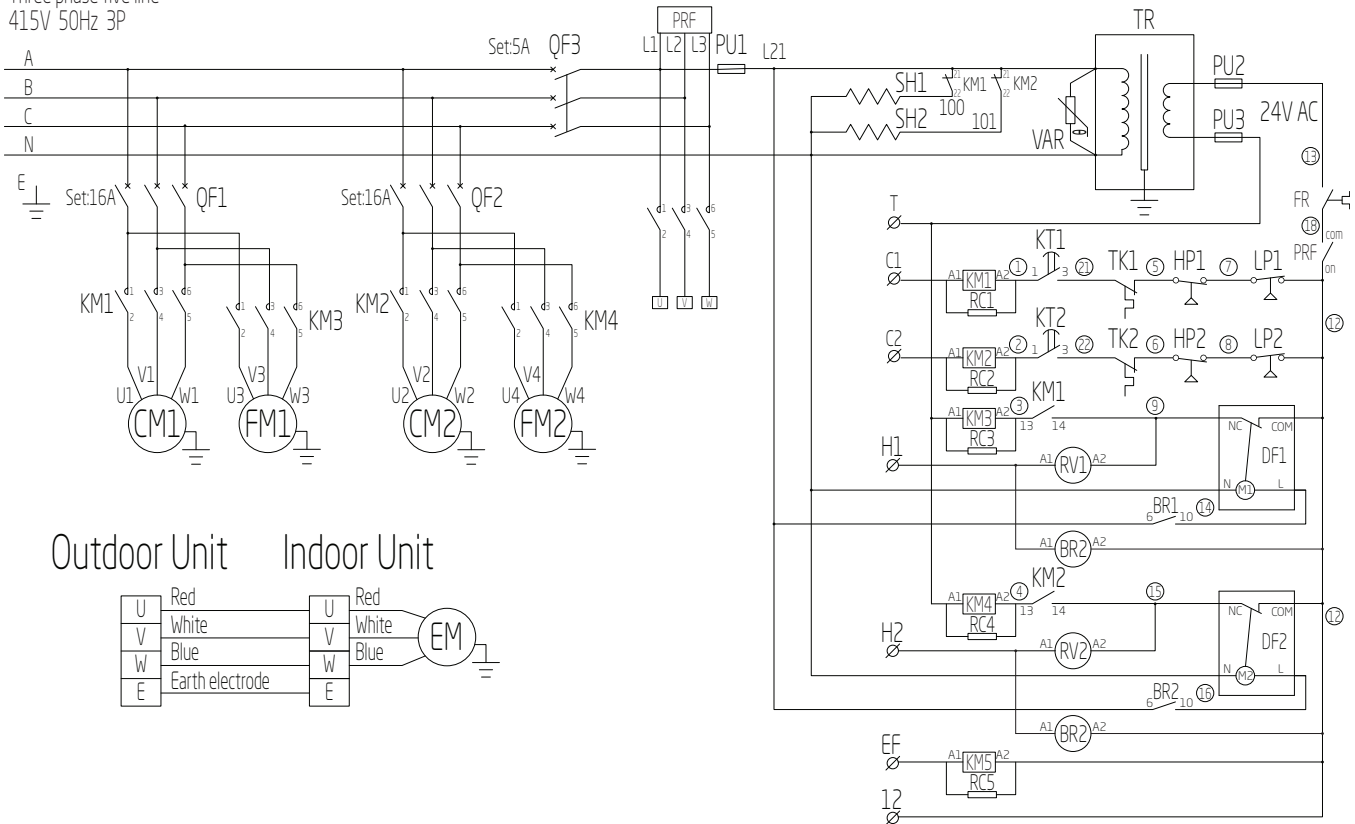

Outdoor Unit Indoor Unit

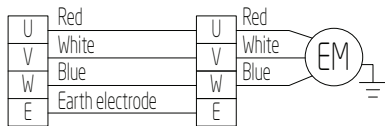

QF1-3	Motor Overload Breaker	VAR	Varistor	RC1-5	Filter	CM1-2	Compressor
KM1-5	Contactor	KT1-2	Time Relay	RV1/RV2	Reversing valve	FM1-4	Condenser fan
FR	Thermal Relay	PRF	Phase Protection	TK1-4	Overload protector	EM	Evaporator fan
TR	Transformer	C1-3	Capacitor	TK5-6	Disch temp sensor	SH1-2	Sump heater
PU1/2/3	Fuse	KA1-2	Fault Relay	L/HP1	HP/LP switch	BR1-2	Bypass Relay
DF1/DF2	De ice						

### SH40-45

Three phase five line  
415V 50Hz 3P

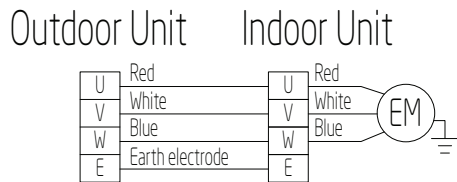
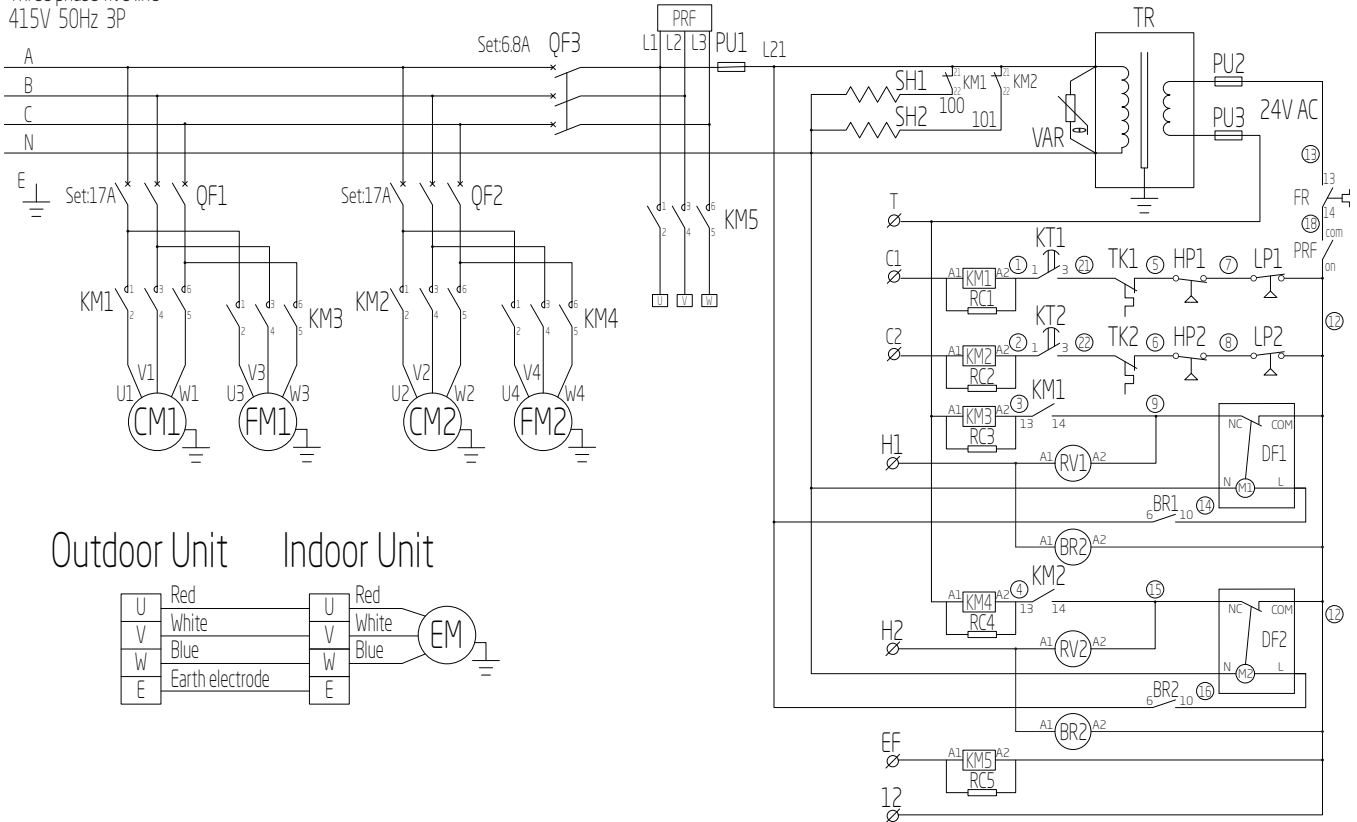

- |         |                        |       |                  |         |                    |       |                |
|---------|------------------------|-------|------------------|---------|--------------------|-------|----------------|
| QF1-3   | Motor Overload Breaker | VAR   | Varistor         | RC1-5   | Filter             | CM1-2 | Compressor     |
| KM1-5   | Contactor              | KT1-2 | Time Relay       | RV1/RV2 | Reversing valve    | FM1-4 | Condenser fan  |
| FR      | Thermal Relay          | PRF   | Phase Protection | TK1-4   | Overload protector | EM    | Evaporator fan |
| TR      | Transformer            | C1-3  | Capacitor        | TK5-6   | Disch temp sensor  | SH1-2 | Sump heater    |
| PU1/2/3 | Fuse                   | KA1-2 | Fault Relay      | L/HP1   | HP/LP switch       | BR1-2 | Bypass Relay   |
| DF1/DF2 | De ice                 |       |                  |         |                    |       |                |

# Wiring Diagrams

## SH50-73

Three phase five line  
415V 50Hz 3P

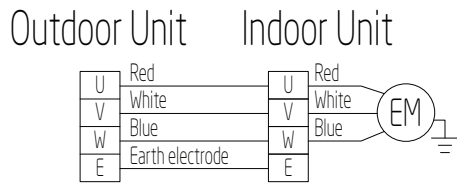
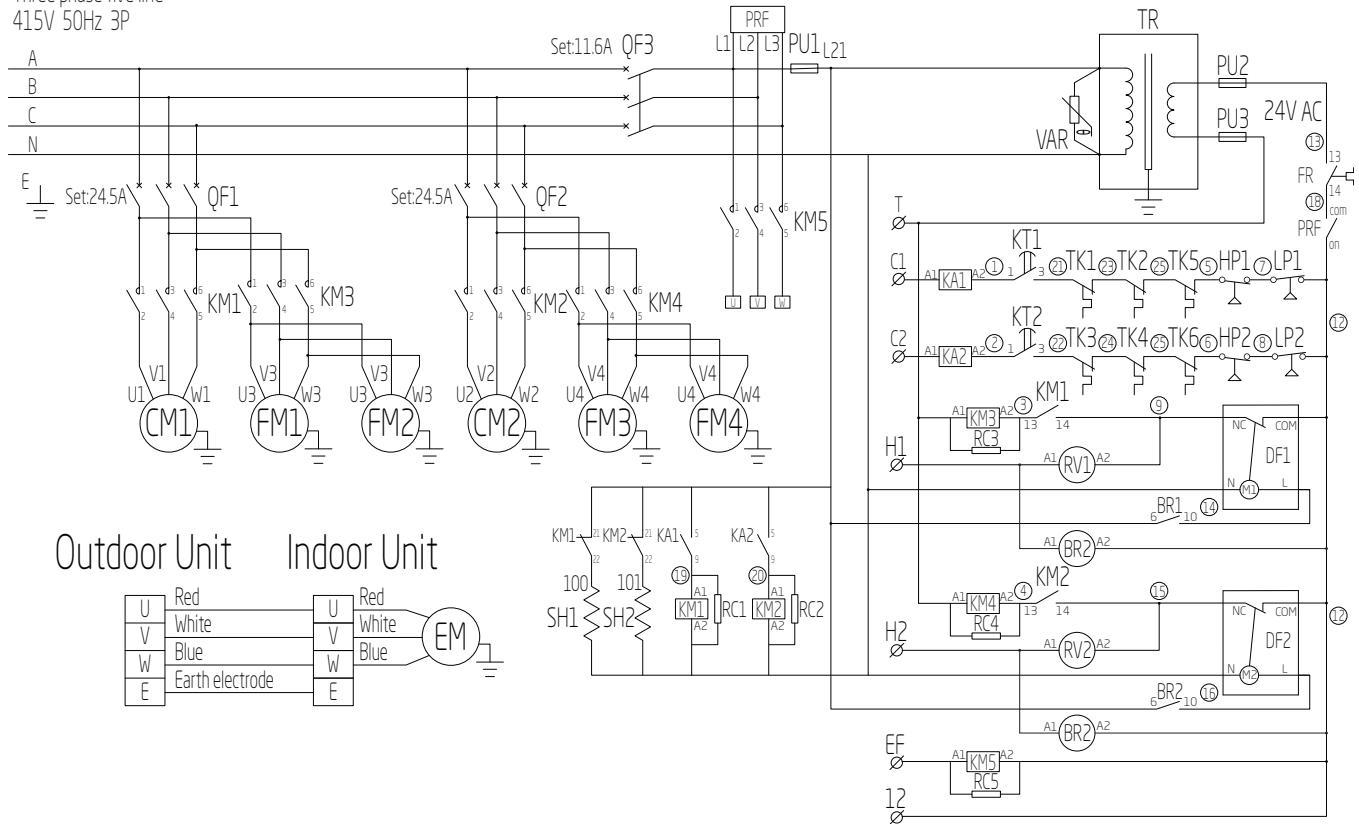

- |         |                        |         |                     |
|---------|------------------------|---------|---------------------|
| QF1-3   | Motor Overload Breaker | RC1-5   | Filter              |
| KM1-5   | Contactor              | RV1/RV2 | Reversing valve     |
| FR      | Thermal Relay          | TK1-4   | Overload protector  |
| TR      | Transformer            | TK5-6   | Disch. temp. sensor |
| PU1/2/3 | Fuse                   | L/HP1-2 | HP/LP switch        |
| DF1/DF2 | De ice                 | CM1/CM2 | Compressor          |
| VAR     | Varistor               | FM1-4   | Condenser fan       |
| KT1-2   | Time Relay             | EM      | Evaporator fan      |
| PRF     | Phase protection       | SH1-2   | Sump heater         |
| KA1-2   | Intermediate relay     | BR1-2   | Bypass Relay        |
| KA3-4   | Fault Relay            |         |                     |

### SH80-200

Three phase five line  
415V 50Hz 3P

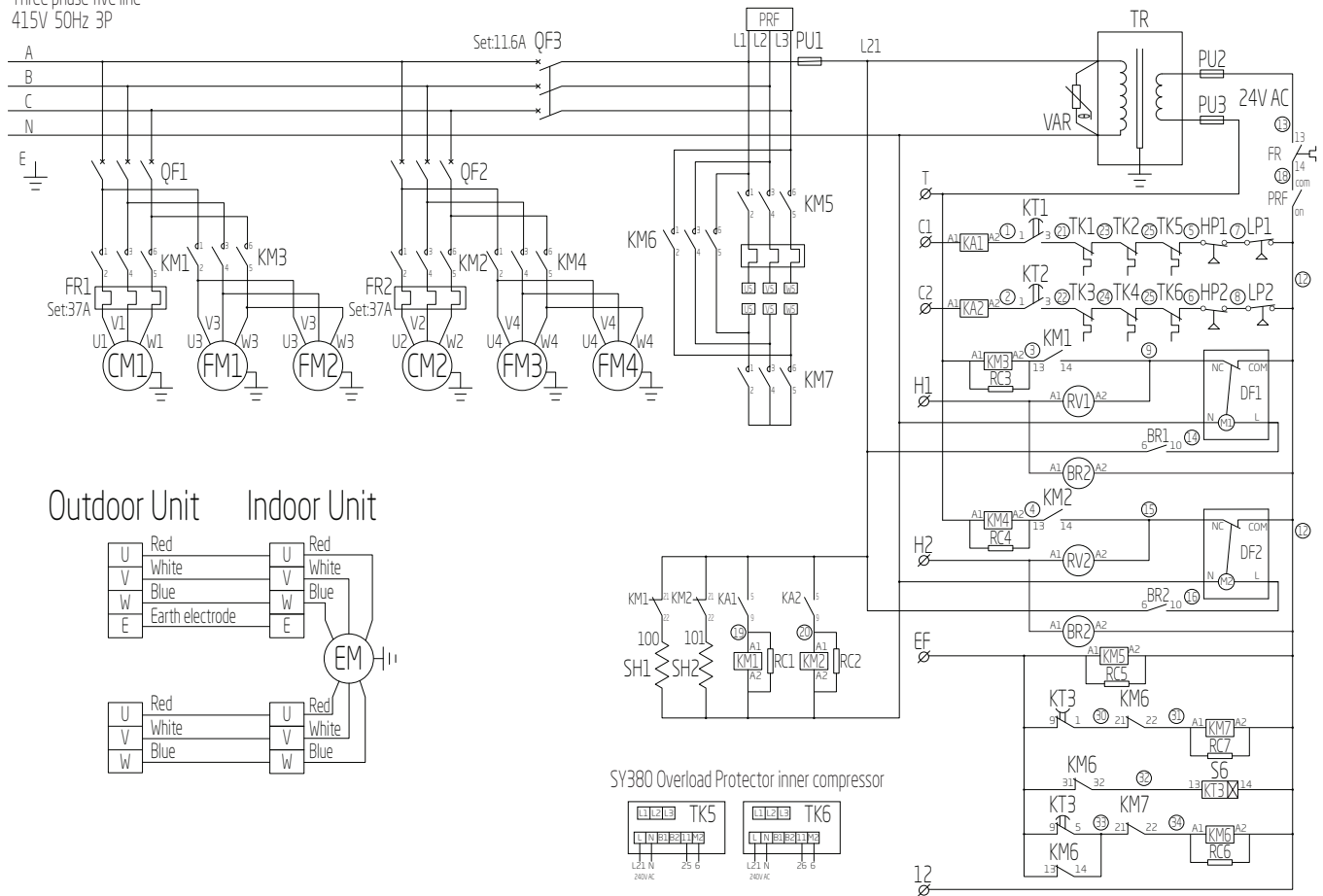

#### Outdoor Unit Indoor Unit

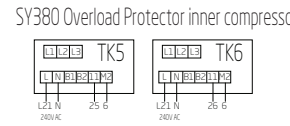
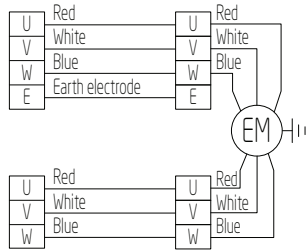

- |         |                        |          |                    |
|---------|------------------------|----------|--------------------|
| QF1-3   | Motor Overload Breaker | RC1-5    | Filter             |
| KM1-5   | Contactor              | RV1/RV2  | Reversing valve    |
| FR      | Thermal Relay          | TK1-4    | Overload protector |
| TR      | Transformer            | L/HP1-2  | HP/LP switch       |
| PU1/2/3 | Fuse                   | CM1 /CM2 | Compressor         |
| DF1/DF2 | De ice                 | FM1-4    | Condenser fan      |
| VAR     | Varistor               | EM       | Evaporator fan     |
| KT1-2   | Time Relay             | SH1-2    | Sump heater        |
| PRF     | Phase Protection       | BR1-2    | Bypass Relay       |
| KA1-2   | Intermediate relay     | TK5      | Compressor protect |
| KA3-4   | Fault Relay            |          |                    |



DUNNAIR (Aust) Pty Ltd

Head Office:

Ashford Avenue, Milperra NSW 2214 P 02 8774 1403

F 02 8774 1490

E [sales.nsw@dunnair.com.au](mailto:sales.nsw@dunnair.com.au)

W [www.dunnair.com.au](http://www.dunnair.com.au)

Dunnair Victoria:

P 03 9558 7001

F 03 9551 1644

E [sales.vic@dunnair.com.au](mailto:sales.vic@dunnair.com.au)

Dunnair Queensland:

P 07 3890 8796

F 07 3890 8642

E [sales.qld@dunnair.com.au](mailto:sales.qld@dunnair.com.au)

For sales in SA, NT or WA please contact our distributor Industrial Air on 08 8354 0088

*Dunnair (Aust) Pty Ltd supports a policy of continuous product improvement. Therefore specification and designs are subject to change without prior notice. Dunnair (Aust) Pty Ltd accepts no responsibility for possible errors in Catalogues, brochures and other printed material. Dunnair is part of the Air Change Group of companies.*



[www.dunnair.com.au](http://www.dunnair.com.au)